

catalogue/
catalogo



INNOVA

volume 6.0

/ these are our

rules of working

-
01

Human relationships

Work now occupies much of our lives. This is why we love building projects and true relationships with our clients.

A strong and positive relationship between client and company is one of our primary goals.

This is the only way we can achieve the best result in every project and have some fun in the process.

Relazioni umane/

Oggi giorno il lavoro impegna gran parte della nostra vita. Per questo ci piace costruire progetti e relazioni vere con i nostri clienti.

Una relazione forte e positiva tra cliente e azienda è uno dei nostri primi obiettivi.

Solo così possiamo ottenere il risultato migliore in ogni progetto e anche divertirci mentre lavoriamo.

-
02

More than Made in Italy

Innova isn't a traditional furniture company. We are more than just the so-called good and beautiful Made in Italy. While the Made in Italy is certainly an added value to our work, it's not the main one.

Non solo Made in Italy/

Innova non è una tradizionale azienda d'arredamento.

Siamo di più del solo e tanto nominato Made in Italy.

Il Made in Italy rappresenta di certo un valore aggiunto per la nostra azienda, ma non è il principale.

-
03

Ethics

We act ethically. Always, working inside the company and in our private lives.

More than a list of rules and principles, it is a true moral code.

It is a force that drives us toward a healthy and pure business.

Etica/

Agiamo secondo etica. Sempre, quando siamo all'interno dell'azienda e nelle nostre vite private.

Non si tratta di una lista di regole e principi, è proprio un codice morale.

È una forza che ci spinge a un business sano e puro.

-
04

Family

We are a family company, founded by Livio Moro, and with a very low staff turnover.

This strong bond, almost like a family, exists among colleagues, but also with our partners.

Kindness, friendliness and transparency are at the base of our way of working and creating relations. Obviously, these values must be mutual.

Famiglia/

Siamo un'azienda familiare, fondata da Livio Moro, con un bassissimo ricambio di persone. Questo legame forte, quasi familiare, è vivo tra colleghi, ma anche con i nostri partner.

Gentilezza, cordialità, chiarezza sono alla base del nostro modo di lavorare e di creare relazioni. Ovviamente, questi valori devono essere reciproci.

-
05

Fresh Thinking

Innova has been operating in the furniture industry since 1982.

We have a great deal of experience and a persistently fresh way of thinking.

Cultivating this fresh way of thinking is the building block of any innovative company. Always one step ahead.

Freschezza di pensiero/

Siamo attivi nel settore dell'arredamento dal 1982. Uniamo grande esperienza e un'irrefrenabile freschezza di pensiero. Coltivare un modo di pensare fresco caratterizza le fondamenta di un'azienda innovativa, sempre un passo avanti.

-
06

True to Our Words

In this field, we are old-fashioned. Holding true to our words is at the root of our way of working. Our words, like a handshake, have the power to build relations founded on trust.

Essere di parola/

In questo caso, siamo all'antica. Per noi essere di parola è alla radice nel nostro modo di lavorare. Una parola, quanto una stretta di mano, hanno la forza per costruire relazioni di fiducia.

-
07

Honesty

We believe that honesty is a fundamental value for building a better society.

This is why we can also admit (eventual) mistakes during our work. Projects can only get better in this way.

Onestà/

Crediamo che essere onesti sia il valore fondamentale per creare una società migliore.

Per questo, sappiamo ammettere anche i nostri (eventuali) errori al lavoro.

Così facendo, ogni progetto può solo diventare migliore.

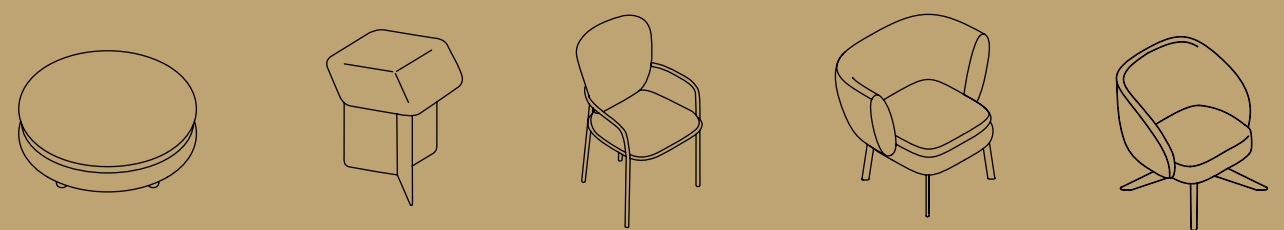
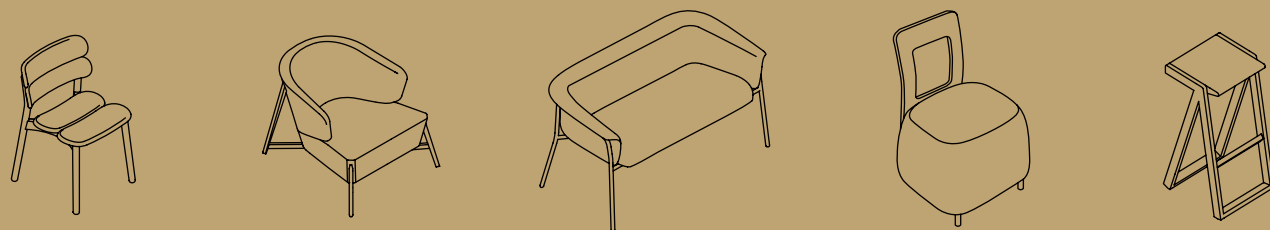

/ company



27

countries where our products are exported
i paesi in cui esportiamo i nostri prodotti

72,000 m

average metres of stitching in a year
i metri di cucitura annua media



998

hospitality structures across the globe
supplied with our products
le strutture ricettive nel mondo rifornite
con i nostri prodotti

1,760,261

average number of people who sit on our
products each year

il numero medio di persone che siedono
sui nostri prodotti ogni anno

138

design and architecture studios with
whom we collaborate each year
gli studi di design e architettura con cui
collaboriamo ogni anno



40,200 m

metres of fabric cut per year
i metri di tessuto tagliati all'anno

13,105

items manufactured every year
i pezzi prodotti all'anno

10%

percentage of revenue reinvested in
product research and development and
marketing

percentuale fatturato investito per la
ricerca e lo sviluppo dei prodotti e per la
loro comunicazione

1982

the year Innova was founded; the
company now boasts 40+ years
of experience in manufacturing
upholstered products

l'anno di fondazione di Innova, che vanta
più di 40 anni di esperienza nella
realizzazione di manufatti imbottiti

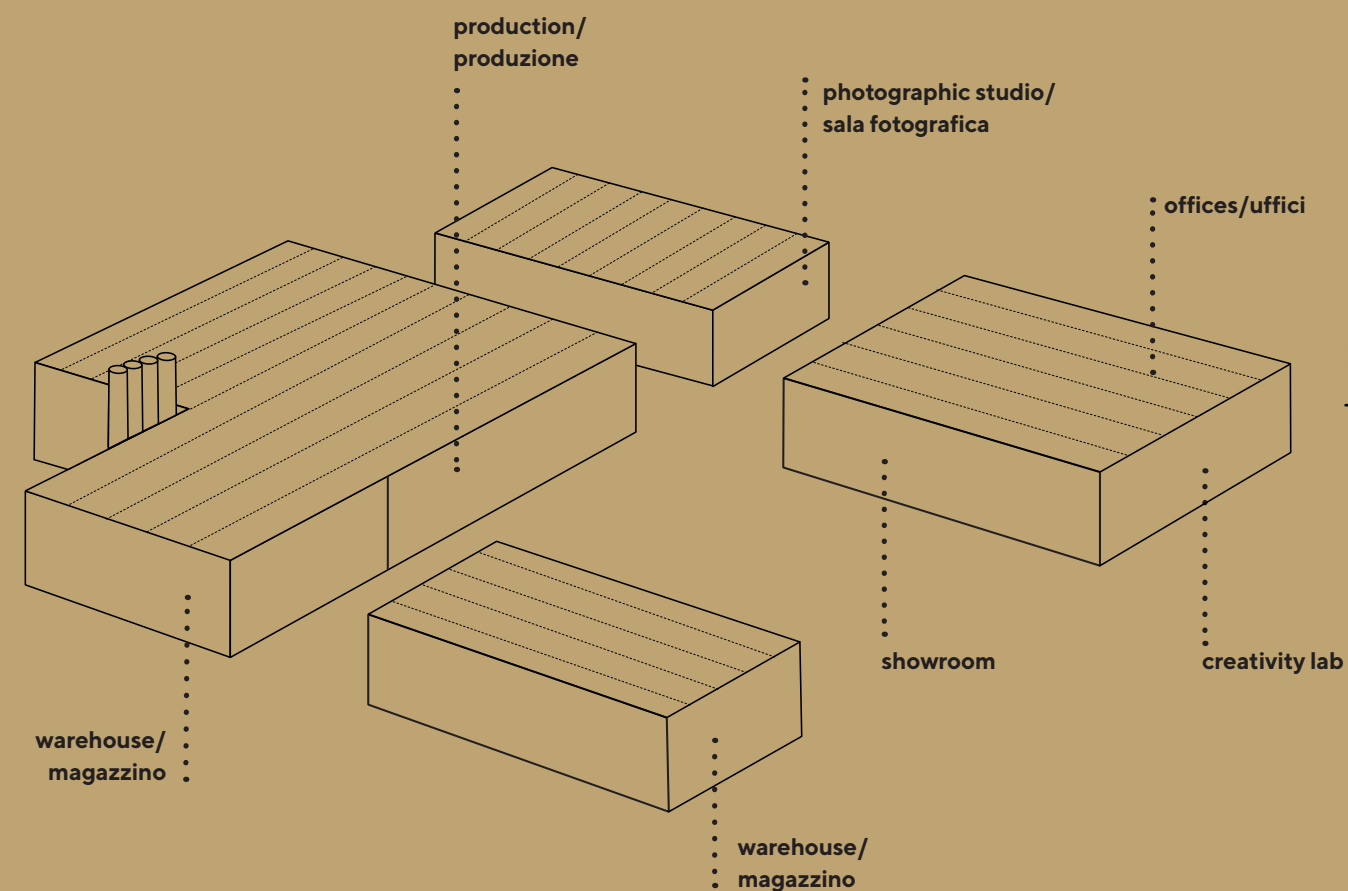

3,800 mq

square metres of manufacturing area
i metri quadri di superficie produttiva in azienda

3,5 h

average number of hours required to
upholster one of our products
le ore in media impiegate per realizzare la
tappeszeria di un prodotto

/ we are not

only products

I

Infinite choice of fabrics

All Innova products can be customised thanks to a choice of fabrics, selected from our vast range or supplied directly by our clients.

Infinite possibilità di tessuti/ Tutti i prodotti di Innova possono essere personalizzati con finiture di tessuto a piacere, scelte fra la vasta selezione interna di tessuti o fornite dal cliente.

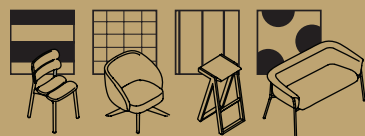

On time

Production times have to be respected because we divide our projects into individual phases, each with its own deadline, while working with an overall vision.

Occhio alla puntualità/ I tempi di realizzo sono rispettati perché dividiamo i progetti in singole fasi, ognuna con la sua scadenza, e ragioniamo con una visione d'insieme.

O

Not just standard

We are the number one fan of our clients. We love listening to their ideas and thinking precisely: for us this means creating the chairs, sofas, footstools and headboards imagined by (and often with) them.

Non solo standard/ Siamo i primi fan dei nostri clienti. Amiamo ascoltare le loro idee e pensare preciso: per noi vuol dire creare proprio quelle poltrone, quei divani, quei pouf, quelle testiere immaginate da (e con) loro.

N

V

Value of Relationships

We consider good relations a value that empowers those who cultivate them. We pursue good relations with both our clients and suppliers; both are extremely important to the lifecycle of any product.

Valore alle relazioni/ Consideriamo le buone relazioni un valore che dà potere a chi le coltiva. Puntiamo a relazioni di valore sia con i clienti che con i fornitori; entrambi sono estremamente importanti nel ciclo di vita del prodotto.



N

Numerous services

We live in a world in which services have become more important than products. For this reason we pay a great deal of attention.

Numerosi servizi/ Viviamo in un mondo dove i servizi sono diventati più importanti dei prodotti, per questo motivo ci mettiamo davvero molta attenzione.



Attentive Listeners

Every project begins with good listening. It is truly important for us to precisely understand the requests made by our clients in order to reach consistently better results.

Ascolto attento/ Ogni buon progetto parte sempre da un buon ascolto. Per noi è davvero importante capire esattamente le richieste del cliente perché il risultato sarà migliore.

A

/ born from

There was once an enterprising and curious young boy. He founded Innova. His name was Livio. As a man, enamoured with life, he used to say: "Attaining a result after dreaming of it for so long helps you understand that nothing is owed, and almost everything costs effort, tears and sweat", as he smiled, calmly.

C'era un ragazzo, intraprendente e curioso. Fu lui a fondare Innova. Si chiamava Livio. Da uomo, innamorato della vita, diceva: conquistare un risultato dopo averlo tanto sognato ti fa capire che nulla è dovuto, e quasi tutto costa fatica, lacrime e sudore" e sorrideva, tranquillo.



/ LEARNING

Livio suggested we always be prepared and reminded us that skills can be learned. He knew this well. As an orphan he had to get busy quickly. With multifaceted experiences and perseverance he learned a great deal and achieved many results. His most important lesson? People are needed to achieve any goal.

Imparare/ Livio suggeriva di prepararsi sempre e ricordava che le competenze si apprendono. Lo sapeva bene. Orfano, dovette darsi da fare presto. Con esperienze poliedriche e perseveranza imparò molto e raggiunse tanti risultati. L'insegnamento più importante? Per raggiungere gli obiettivi servono le persone.

/ BUILDING

Sometimes, you need to know how to recognise your limits to build and achieve good results. A few steps back can generate momentum for huge leaps forward.

Costruire/ A volte per riuscire a costruire e ottenere buoni risultati bisogna saper riconoscere i propri limiti. Qualche passo indietro può dare lo slancio per enormi salti in avanti.

/ PASSING FOWARD

These inspirations are the legacy that Livio gifted us in 2020, the ideas he used to shape our way of working. In their wake, we continue to take Innova forward.

Tramandare/ Queste ispirazioni sono l'eredità che Livio ci ha lasciato nel 2020, le idee con le quali ha plasmato il nostro modo di lavorare. Sulla loro scia, continuiamo il cammino di Innova.

/ INVOLVING OTHERS

Human beings must be considered before their skills. Because skills can be developed, humanity less so. This is why it is essential to encourage free expression and find the way to make everyone's special qualities flourish. They will attain unexpected results.

Coinvolgere/ L'essere umano va considerato prima delle sue competenze. Perché le competenze si sviluppano, l'umanità meno. Per questo è essenziale incentivare la libera espressione e trovare il modo per far fiorire le peculiarità di ciascuno. Daranno risultati insperati.

/ FACING THE FUTURE

The safest route is not always the most successful. A few risks need to be taken when facing the future. This is the best way to innovate and progress.

Affrontare il futuro/ Seguire la via più sicura non sempre dà risultati. Per affrontare il futuro è bene assumersi qualche rischio. È il modo migliore per innovare e progredire.

“We are maker of blank pages.”

Many people tell you what you can and cannot do. Here at Innova, we give you the opportunity to range. This is why we define ourselves as “producers of white pages”, sheets that are drawn and coloured from your ideas. We can create the product with the style you imagined, from fabric to finishing, or even designed from your sketch. Thank to our experience we will drive you throughout the whole manufacturing process.

“Siamo produttori di pagine bianche.”

Molti ti dicono cosa puoi o non puoi fare. Noi di Innova ti diamo la possibilità di spaziare. Per questo ci definiamo “produttori di pagine bianche”, fogli che vengono disegnati e colorati dalle tue idee. Siamo in grado di confezionare il prodotto dello stile che immagini tu, per tessuto o finitura, o anche disegnato da zero. Con la nostra esperienza ti accompagneremo lungo tutto il processo di realizzazione.

/ contents

Chair



Turtle & Turte arm	18
Bands & Bands arm	20
Izzy & Izzy open	22
Arena	24
Art	26
Opera & Opera arm	28
Soho & Soho arm	30

/Dining chair

Rivoli tall & short	32
Rivoli arm	34
Amélie	36
Heo	38
Mies & Mies arm	40
Twiggy & Twiggy arm	42
Twin & Twin arm	44
Eleven & Eleven arm	46
Athena	48

Armchair



Thea	52
Look & Look open	54
Diamond	56
Bloom	58
Shell	60
Kuma & Kuma open	62
Olie	64
Noem	76
Kat	78
Little Cloud	80

/Lounge

Olie lounge	66
Curvy	68
Hug	70
Bloom lounge	72
Tera	74
Cloud	82
Smoky low	84
Smoky medium	86
Smoky high	88
Bands bergère	90
Bands lounge	92
Arsenale GL1	94
Arsenale LC1	96
Kyo	98
Bisy	100
Look lounge	102
Adam	104
Adam high	106
Circus low	108
Circus high	110
Berg low	112
Berg high	114
Nobu	116
Eleven	118
Otta	120
Mella	122

Sofa



Kat	126
Kyo	128
Arsenale GL1	130
Arsenale LC1	132
Arsenale chaise longue	134
Circus low	136
Circus high	138
Adam	140
Adam daybed	142
Berg	144
Brezza	146
Noa	148
Nobu	150

Not ordinary



Vice-versa	154
Mella	158
Moka	160
Ness	162
Macaron	164

Barstool



Sgabby	168
Turtle	170
Ness	171
Soho	172
Rivoli	173
Look	174
Wave	175
Izzy & Izzy open	176
Diamond	177

Complement



/Pouf

Macaron	181
Gin	181
Tonic	181
Drum	182
Taco	182
Adam	182
Sky	183
Berg	183
Cloud	183
Vice-versa	184
Moka	185
Neep & Noop	186
Ness	186
Cushions/ Cuscini	187

/Tables

Moka	189
Tube	190
Tulu	191
Levante	192
Rosie	193
Gio	194
Layers	196
Ness	197
Tala	198

/Carpet

Airy	200
Dori	201

Families & Technical info

Families\ Famiglie	202
Finishing\ Finiture	210
Design feel	214



“How we design products”

What is the most comfortable way to experience a product? This is difficult to understand from photographs, but simple using our indicators. We can immediately reveal their meaning and help you understand them right away.

Come è più comodo da vivere un prodotto? Difficile capirlo dalle foto, semplice con i nostri indicatori. Ti sveliamo il loro significato e capirai al volo i prodotti.

Regular seating

A seat that helps you assume a composed stand, with a straight back, respecting all the rules of good etiquette.



Seduta regolare

È una seduta che ti accompagna ad assumere una posizione composta, con la schiena dritta, degna del galateo.

Lounge seating

Here you can stretch out and relax a little bit, while maintaining the necessary “decorum”.



Seduta comoda

Qui puoi allungarti e rilassarti un po’, mantenendo ancora il cosiddetto un di “decoro”.

Loose seating

We reach another level. Unplug and think about what you want, in freedom!



Seduta spensierata

Passiamo a un altro livello. Stacca la spina e pensa a ciò che vuoi, in libertà!

Bold seating

Grandma wouldn’t approve... But it’s so comfortable and inviting, to be interpreted as one wishes.



Seduta sfacciata

La nonna non approverebbe... Però è tutto comodo e invitante, da interpretare a piacere.

**“COMFORTABLE SEATING, FOR ALL TASTES ”
“ SEDUTE COMODE, PER TUTTI I GUSTI ”**

Alongside tables and small tables for cafés and restaurants, to desks or meeting room tables, to hotel rooms or conference halls.

Whatever their use, chairs must be solid and comfortable, and with a refined and personal style.

Innova offers a complete and versatile collection of seats.

All our chairs can be personalised, because they offer the possibility to combine each structure, always padded and upholstered with fabric, with a range of available bases, choosing between wood or metal and among many forms, from the most classic to the most modern.

Accanto a tavoli e tavolini di caffè e ristoranti, alla scrivania o al tavolo da riunione, in camere d'albergo o in una sala conferenze.

Qualunque sia la loro destinazione, è importante che le sedie siano solide e comode, e con uno stile curato e personale.

Innova propone una collezione completa e versatile di sedute.

Sono tutte personalizzabili, perché offrono la possibilità di abbinare ogni scocca, sempre imbottita e rivestita in tessuto, con i diversi basamenti disponibili, scegliendo tra legno o metallo e tra molte forme, dalla più classica alla più moderna.

chair



turtle

It is strong, strong as the tortoise' shell. And like that shell, it is rich in carvings, perfectly joined together. It is never in rush, Turtle. She is always ready for a break.

Robusta, è robusta, come la corazza di una tartaruga. Come quel guscio, è ricca di intagli, perfettamente uniti fra loro. Non ha mai fretta, Turtle. È sempre pronta per una pausa.



\DESCRIPTION

Solid beech wood structure, backrest and seat in curved plywood with expanded polyurethane foam, upholstered with fabric.

Weight: kg 5

Required fabric: 2,20 m. (h 1,40).

Other combinations of fabrics available on request. *consumptions based on fabrics without pattern.

\DESCRIZIONE

Struttura della base in massello di faggio, schienale e seduta in multistrato curvato, imbottiti con poliuretano espanso a quote differenziate, rivestiti in tessuto.

Peso: kg 5

Tessuto occorrente: 2,20 mt. (h 1,40).

Altre combinazioni di tessuti disponibili su richiesta. *consumi calcolati con tessuti senza rapporto.

F FAMILY

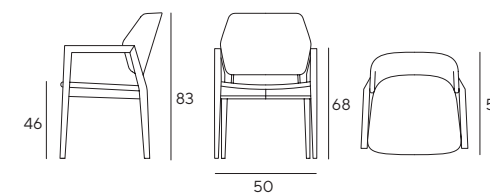

For the bases finishing, see on page 212
Per le finiture dei basamenti vedi pag. 212

 11M UNI 9175
OMOLOGATO

bands



Bands is a chair with a simple look, yet very distinctive. The repetition of the only structural element creates the seat and the backrest, available also with armrests.

Bands è una sedia dall'aspetto semplice eppure molto riconoscibile. La ripetizione di un unico elemento accoppiato crea sedile e schienale, anche con braccioli.

\DESCRIPTION

Solid beech wood structure, backrest and seat in curved plywood with expanded polyurethane foam, upholstered with fabric.

Weight: from kg 7 to 8

Required fabric: Bands 1,60 m. (h 1,40)

Bands arm 2,50 m. (h 1,40).

Other combinations of fabrics available on request. *consumptions based on fabrics without pattern.

\DESCRIZIONE

Struttura della base in massello di faggio, schienale e seduta in multistrato curvato, imbottiti con poliuretano espanso a quote differenziate, rivestiti in tessuto.

Peso: da kg 7 a 8

Tessuto occorrente: Bands 1,60 mt. (h 1,40)

Bands arm 2,50 mt. (h 1,40).

Altre combinazioni di tessuti disponibili su richiesta. *consumi calcolati con tessuti senza rapporto.

F FAMILY

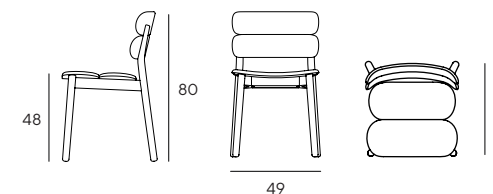

For the bases finishing, see on page 212
Per le finiture dei basamenti vedi pag. 212

11M UNI 9175
OMOLOGATO

izzy



A chair with soft shapes and an essential profile. It can be personalised with relief stitching upon request, different legs and bases and an added opening on the back that introduces a touch of lightness.

Una sedia dalle forme morbide e dal profilo essenziale. È personalizzabile con cuciture a rilievo su richiesta, con gambe e basamenti diversi e con l'apertura sulla schiena per dare un tocco di leggerezza.

\DESCRIPTION

Steel framework, entirely moulded in cold-cure polyurethane.

Weight: from kg 7 to 13

Required fabric: 1,10 m. (h 1,40)

Other combinations of fabrics available on request.
*consumptions based on fabrics without pattern.

\DESCRIZIONE

Struttura della scocca in acciaio, interamente stampata in poliuretano schiumato a freddo.

Peso: da kg 7 a 13

Tessuto occorrente: 1,10 mt. (h 1,40)

Altre combinazioni di tessuti disponibili su richiesta.
*consumi calcolati con tessuti senza rapporto.

F FAMILY



L17



L9



P2 (fissa/fixe)
P10 (girevole/swivelling)



S3



R15



N1



NIR



R1

Upholstery optional
Variante di tappezzeria opzionale

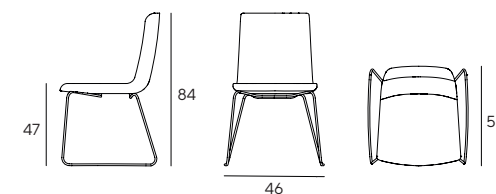



arena

Regardless of the legs or base selected, the profile of this model remains unmistakable: open, inviting and reminiscent of a classical amphitheatre.

Qualsiasi siano le gambe o il basamento scelto, il profilo di questo modello è inconfondibile: aperto e accogliente, ricorda un anfiteatro classico.



volume 6.0 | INNOVA

volume 6.0 | INNOVA

\DESCRIPTION

Steel framework, entirely moulded in cold-cure polyurethane.

Weight: from kg 7 to 13

Required fabric: 1,20 m. (h 1,40)

Other combinations of fabrics available on request.

*consumptions based on fabrics without pattern.

\DESCRIZIONE

Struttura della scocca in acciaio, interamente stampata in poliuretano schiumato a freddo.

Peso: da kg 7 a 13

Tessuto occorrente: 1,20 mt. (h 1,40)

Altre combinazioni di tessuti disponibili su richiesta.

*consumi calcolati con tessuti senza rapporto.

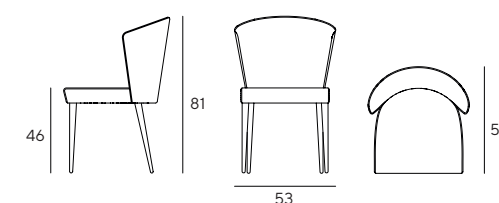

PICTURE BASES= GL

For the bases finishing, see on page 212
Per le finiture dei basamenti vedi pag. 212





Almost a small armchair, very compact with a special care in the exposed stitching and tapered legs, finished, upon request, to become one with the back. Simply impeccable.

Quasi una poltroncina, molto compatta e curata nelle cuciture a vista e nelle gambe affusolate e rivestite, a richiesta, fino a diventare un tutt'uno con lo schienale. Impeccabile.

\DESCRIPTION

Steel framework, entirely moulded in cold-cure polyurethane.
Legs in ash wood, stained or raw.
The legs could be covered in fabric or leather.

Weight: kg 9

Required fabric: 1,50 m. (h 1,40).
Other combinations of fabrics available on request. *consumptions based on fabrics without pattern.

\DESCRIZIONE

Struttura in acciaio, interamente stampata in poliuretano schiumato a freddo. Gambe in legno di frassino grezze o verniciate. Le gambe possono essere rivestite in pelle o tessuto.

Peso: kg 9

Tessuto occorrente: 1,50 mt. (h 1,40).
Altre combinazioni di tessuti disponibili su richiesta. *consumi calcolati con tessuti senza rapporto.

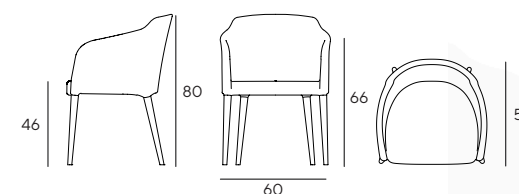

PICTURE BASES= BLUE WITH UPHOLSTERED LEGS

For the bases finishing, see on page 212
Per le finiture dei basamenti vedi pag. 212

opera

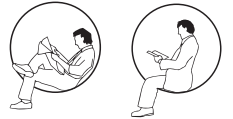

The modern techniques of production open the possibility to details and new forms that transform a classic chair in a piece of design by strong personality.

Le moderne tecniche di produzione aprono la possibilità a dettagli e forme nuove che trasformano una sedia classica in un pezzo di design dalla forte personalità.



\DESCRIPTION

Steel framework, entirely moulded in cold-cure polyurethane with ash wood base.

Weight: Opera kg 10- Opera arm kg 11

Required fabric: Opera 1,10 m. (h 1,40)

Opera arm 1,50 m. (h 1,40) .

Other combinations of fabrics available on request. *consumptions based on fabrics without pattern.

\DESCRIZIONE

Struttura della scocca in acciaio, interamente stampata in poliuretano schiumato a freddo con basamento in legno di frassino.

Peso: Opera kg 10- Opera arm kg 11

Tessuto occorrente: Opera 1,10 mt. (h 1,40)

Opera arm 1,50 mt. (h 1,40)

Altre combinazioni di tessuti disponibili su richiesta. *consumi calcolati con tessuti senza rapporto.

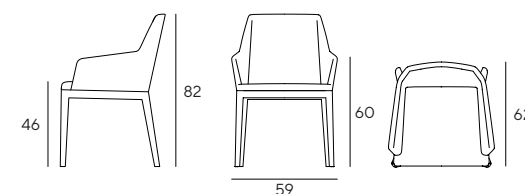

For the bases finishing, see on page 212
Per le finiture dei basamenti vedi pag. 212

soho



There is only one mantra for Soho: freedom, vivacity, youth and freshness. The clean structure of the base embraces the backrest... it is a play of contrasts between fabric and wood. Striking!

C'è un solo mantra, per Soho: libertà, vivacità, giovinezza e freschezza. La struttura pulita della base abbraccia lo schienale... è un gioco di contrasti fra tessuto e legno. D'impatto!

\DESCRIPTION

Solid beech wood structure, backrest and seat in curved plywood with expanded polyurethane foam, upholstered with fabric.

Weight: kg 6

Required fabric: 1,10 m. (h 1,40).

Other combinations of fabrics available on request. *consumptions based on fabrics without pattern.

\DESCRIZIONE

Struttura della base in massello di faggio, schienale e seduta in multistrato curvato, imbottiti con poliuretano espanso a quote differenziate, rivestiti in tessuto.

Peso: kg 6

Tessuto occorrente: 1,10 mt. (h 1,40).

Altre combinazioni di tessuti disponibili su richiesta. *consumi calcolati con tessuti senza rapporto.

F FAMILY

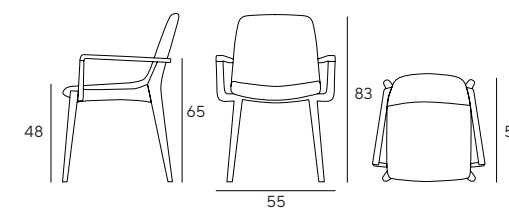

For the bases finishing, see on page 212
Per le finiture dei basamenti vedi pag. 212

 11M UNI 9175
OMOLOGATO

rivoli tall & short

Elegant shapes and comfort to stand out.
Fabric and wood, combined to fascinate.
A sophisticated base that slims and provides security. Très chic.

Forme eleganti e comodità per distinguersi.
Tessuto e legno, abbinati per affascinare.
È un basamento sofisticato per slanciare e dare sicurezza. Très chic.



\DESCRIPTION

Solid beech wood structure, backrest and seat in curved plywood with expanded polyurethane foam, upholstered with fabric.

Weight: Rivoli short kg 5 - Rivoli tall kg 5,5

Required fabric: Rivoli short 1,10 m. (h 1,40)
Rivoli tall 1,10 m. (h 1,40)

Other combinations of fabrics available on request. *consumptions based on fabrics without pattern.

\DESCRIZIONE

Struttura della base in massello di faggio, schienale e seduta in multistrato curvato, imbottiti con poliuretano espanso a quote differenziate, rivestiti in tessuto.

Peso: Rivoli short kg 5 - Rivoli tall kg 5,5

Tessuto occorrente: Rivoli short 1,10 mt. (h 1,40)
Rivoli tall 1,10 mt. (h 1,40)

Altre combinazioni di tessuti disponibili su richiesta. *consumi calcolati con tessuti senza rapporto.

F FAMILY



RIVOLI TALL



RIVOLI SHORT

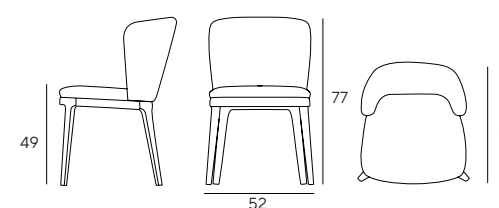

For the bases finishing, see on page 212
Per le finiture dei basamenti vedi pag. 212

11M UNI 9175
OMOLOGATO

rivoli arm



Rivoli arm is the truly comfortable choice. Its enveloping shape enriched by armrests is ideal for sophisticated dining rooms, embellished by the Parisian style.

Rivoli arm è la scelta comoda assai. La sua forma avvolgente arricchita dai braccioli è ideale per sale da pranzo sofisticate, impreziosite dallo stile parisiense.

\DESCRIPTION

Ash wood base, backrest and seat in curved plywood with expanded polyurethane foam, upholstered with fabric.

Weight: kg 6,5

Required fabric: 1,70 m. (h 1,40).

Other combinations of fabrics available on request. *consumptions based on fabrics without pattern.

\DESCRIZIONE

Struttura della base in frassino, schienale e seduta in multistrato curvato, imbottiti con poliuretano espanso a quote differenziate, rivestiti in tessuto.

Peso: kg 6,5

Tessuto occorrente: 1,70 mt. (h 1,40).

Altre combinazioni di tessuti disponibili su richiesta. *consumi calcolati con tessuti senza rapporto.

F FAMILY

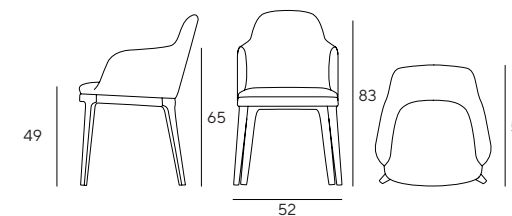

For the bases finishing, see on page 212
Per le finiture dei basamenti vedi pag. 212

 11M UNI 9175
OMOLOGATO

amélie

Even the fabulous world of our Amélie opens up to the imagination: a simple and welcoming seat for playing with new realities, between bases and fabrics. Perfect for the contract market.

Anche il favoloso mondo della nostra Amélie apre all'immaginazione: una seduta semplice e accogliente con la quale giocare a nuove realtà fra basamenti e tessuti. Perfetta per il contract.

Steel framework, entirely moulded in cold-cure polyurethane.

Struttura della scocca in acciaio, interamente stampata in poliuretano schiumato a freddo.

Weight: from kg 12 to 14

Required fabric: standard product 1,70m. (h 1,40)/ with piping 2,00 m. (1,40)

Other combinations of fabrics available on request. *consumptions based on fabrics without pattern.

Peso: da kg 12 to 14

Tessuto occorrente: prodotto standard 1,70 mt. (h 1,40)/ con filetto 2,00 mt. (1,40)

Altre combinazioni di tessuti disponibili su richiesta. *consumi calcolati con tessuti senza rapporto.



L17



L13 P



R1



P2 (fissa/fixe)
P10 (girevole/swivelling)



C1



R15



N1



N1R

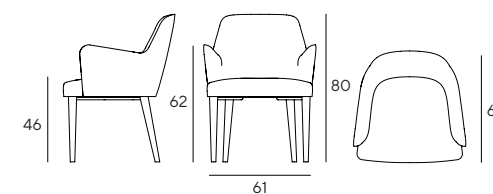

PICTURE BASES= FROM LEFT L13P - N1R

For the bases finishing, see on page 212
Per le finiture dei basamenti vedi pag. 212



heo



Shapes so simple they become unique.
Heo is soft and welcomes you in a large seat.
Perfectly in different contexts: change the base
and, voila, a new product is created.

Forme talmente semplici da divenire uniche.
Heo è morbida e accogliente in un'ampia seduta.
Perfetta in diversi contesti: cambia il basamento
e, voilà, un nuovo prodotto si crea.

\DESCRIPTION

Entirely moulded in cold-cure polyurethane.

Weight: kg 7,5

Required fabric: 1,50 m. (h 1,40)

Other combinations of fabrics available on
request. *consumptions based on fabrics
without pattern.

\DESCRIZIONE

Interamente stampata in poliuretano
schiumato a freddo.

Peso: kg 7,5

Tessuto occorrente: 1,50 mt. (h 1,40)

Altre combinazioni di tessuti disponibili
su richiesta. *consumi calcolati con tessuti
senza rapporto.

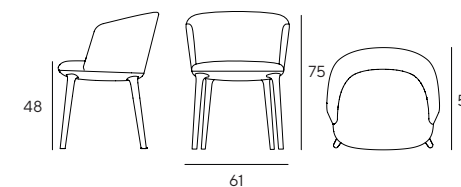

For the bases finishing, see on page 212
Per le finiture dei basamenti vedi pag. 212



mies

A tribute to a great master: essentiality and simplicity characterise the repeated rays of the structure and the illusion of a suspended seat.

Un omaggio a un grande maestro: essenzialità e semplicità caratterizzano i raggi ripetuti della struttura e l'illusione della sospensione della seduta.



\DESCRIPTION

Metal structure, backrest and seat in curved plywood with expanded polyurethane foam.

Weight: 10 kg

Required fabric: 1,40 m. (h 1,40).

Other combinations of fabrics available on request. *consumptions based on fabrics without pattern.

\DESCRIZIONE

Struttura della base in metallo, schienale e seduta in multistrato e curvato, imbottiti con poliuretano espanso a quote differenziate.

Peso: 10 kg

Tessuto occorrente: 1,40 mt. (h 1,40).

Altre combinazioni di tessuti disponibili su richiesta. *consumi calcolati con tessuti senza rapporto.

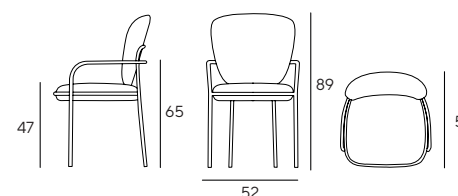

For the bases finishing, see on page 212
Per le finiture dei basamenti vedi pag. 212



twiggy

Our Twiggy is ironic and elegant. It has different bases, thin and slender, and a seat with or without armrests, always with a pop opening.

La nostra Twiggy è ironica ed elegante. Propone diversi basamenti, sottili e slanciati, e una seduta con o senza braccioli, sempre con un'apertura pop.



PICTURE BASES= METAL N1 - WOOD L 12

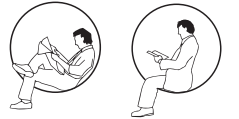

\DESCRIPTION

Steel framework, entirely moulded in cold-cure polyurethane.

Weight: from kg 9 to 15

Required fabric: Twiggy 1,30 m. (h 1,40)

Twiggy arm 1,50 m. (h 1,40)

Other combinations of fabrics available on request.

*consumptions based on fabrics without pattern.

\DESCRIZIONE

Struttura della scocca in acciaio, interamente stampata in poliuretano schiumato a freddo.

Peso: da kg 9 a 15

Tessuto occorrente: Twiggy 1,30 mt. (h 1,40)

Twiggy arm 1,50 mt. (h 1,40)

Altre combinazioni di tessuti disponibili su richiesta.

*consumi calcolati con tessuti senza rapporto.



L7



L17



L12



P2 (fissa/fix)
P10 (girevole/swivelling)



C1



R15



R1



P9

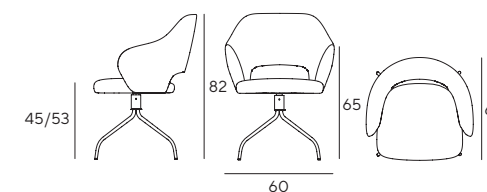

For the bases finishing, see on page 212
Per le finiture dei basamenti vedi pag. 212



— twin



The rigid backrest coupled with the soft padding plays the main role in the Twin collection. It leaves the freedom to combine contrasting colours and finishes or to match them.

Lo schienale rigido accoppiato con l'imbottitura morbida diventa protagonista nella collezione Twin. Lascia la libertà di combinare colori e finiture a contrasto o in abbinamento tra di loro.

Structure entirely moulded in flexible polyurethane, backrest with varnished rigid polyurethane insert. Expanded polyurethane seat with wooden frame.

Struttura stampata interamente in poliuretano flessibile, schienale con inserto in poliuretano rigido verniciato. Sedile in poliuretano espanso con struttura in legno.

Weight: twin from kg 8 to 13, arm from kg 10 to 15
Required fabric: twin 1,20 m. (h 1,40)/
 twin arm 2,00 m. (1,40)
 Other combinations of fabrics available on request.
 *consumptions based on fabrics without pattern.

Peso: twin da kg 8 a 13, arm da kg 10 a 15
Tessuto occorrente: twin 1,20 mt. (h 1,40)
 twin arm 2,00 mt. (1,40)
 Altre combinazioni di tessuti disponibili su richiesta.
 *consumi calcolati con tessuti senza rapporto.



volume 6.0 | INNOVA

volume 6.0 | INNOVA

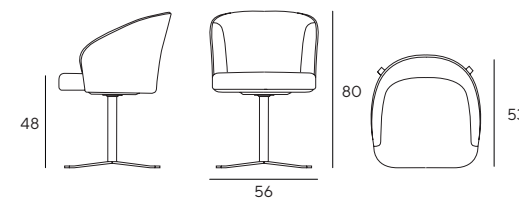

PICTURE BASES= FROM LEFT L13P - R1

For the bases finishing, see on page 212
 Per le finiture dei basamenti vedi pag. 212



eleven



Soft drapes and immediate comfort: these are what distinguishes the Eleven collection. From armchairs to dining chairs, small and practical to fill any room.

Drappeggi morbidi e confortevolezza immediata: è questo che contraddistingue la collezione Eleven. Dalla poltrona alle dining chair, piccole e pratiche per riempire ogni ambiente.

Steel framework, entirely moulded in cold-cure polyurethane.

Struttura della scocca in acciaio, interamente stampata in poliuretano schiumato a freddo.

Weight: from kg 8 to 12
Required fabric: eleven 1,30 m. (h 1,40)
 eleven arm 1,70 m. (h 1,40)
 Other combinations of fabrics available on request.
 *consumptions based on fabrics without pattern.

Peso: da kg 8 to 16
Tessuto occorrente: eleven 1,30 m. (h 1,40)
 eleven arm 1,70 m. (h 1,40)
 Altre combinazioni di tessuti disponibili su richiesta.
 *consumi calcolati con tessuti senza rapporto.

F FAMILY

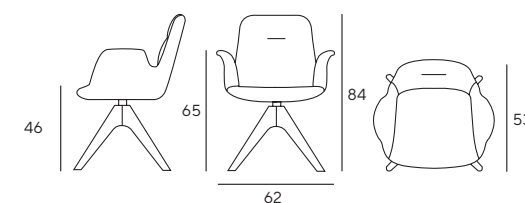

For the bases finishing, see on page 212
 Per le finiture dei basamenti vedi pag. 212

PICTURE BASES= FROM LEFT L17 - P2



athena



Athena is sensuality and strength at the same time. The frame with soft but decisive shapes supports the seat and the sinuous backrest.

Athena è sensualità e allo stesso tempo forza. Il telaio dalle forme morbide ma decise sorregge la seduta e lo schienale sinuoso.

\DESCRIPTION

Metal varnished frame, supporting structure in rigid polyurethane with ultra soft expanded polyurethane foam.

Weight: 9 kg

Required fabric: 1,50 m. (h 1,40).

Other combinations of fabrics available on request. *consumptions based on fabrics without pattern.

\DESCRIZIONE

Basamento in metallo verniciato, struttura portante in poliuretano rigido con imbottitura in poliuretano espanso ultra soft.

Peso: 9 kg

Tessuto occorrente: 1,50 mt. (h 1,40).

Altre combinazioni di tessuti disponibili su richiesta. *consumi calcolati con tessuti senza rapporto.

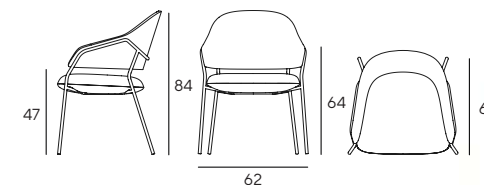

For the bases finishing, see on page 212
Per le finiture dei basamenti vedi pag. 212



**“COMPLETE COMFORT, AND TOTAL PERSONALISATION”
“UN COMFORT COMPLETO, TUTTO DA PERSONALIZZARE”**

Different shapes, colours and materials distinguish Innova’s rich collection of armchairs and small armchairs. From the classic bergère to the space-saving armchair, these padded seats are ideal for the broadest range of contract venues, from the hotel room to corporate environments, but also in domestic contexts. This is especially true of more enveloping models with footrests.

Comfortable and resistant, our armchairs can be personalised with different upholstery and a range of available bases. Wood presents a more natural style, while metal offers a more contemporary footprint.

Forme, colori e materiali sempre diversi contraddistinguono la ricca collezione di poltrone e poltroncine di Innova. Dalla classica bergère alla poltroncina compatta, queste sedute imbottite sono ideali per i più diversi luoghi del contract, dalla camera d’albergo agli ambienti corporate, ma anche all’interno di contesti domestici, soprattutto nel caso dei modelli più avvolgenti e con poggiatesta.

Confortevoli e resistenti, le poltrone si possono personalizzare con i diversi rivestimenti e le molte basi disponibili. Il legno dà uno stile più naturale, il metallo un’impronta più contemporanea.



thea



Thea features a design with sharp lines, especially thanks to the two curves that meet as if in a hug and surround the soft and welcoming structure.

Thea presenta un design dalle linee decise, in particolare grazie alle due curve che si incontrano come in un abbraccio e circondano la struttura morbida e accogliente.

\DESCRIPTION

Metal varnished frame, supporting structure in rigid polyurethane with ultra soft expanded polyurethane foam.

Weight: kg 10

Required fabric: 1,80 m. (h 1,40).

Other combinations of fabrics available on request. *consumptions based on fabrics without pattern.

\DESCRIZIONE

Basamento in metallo verniciato, struttura portante in poliuretano rigido con imbottitura in poliuretano espanso ultra soft.

Peso: kg 10

Tessuto occorrente: 1,80 mt. (h 1,40).

Altre combinazioni di tessuti disponibili su richiesta.

*consumi calcolati con tessuti senza rapporto.

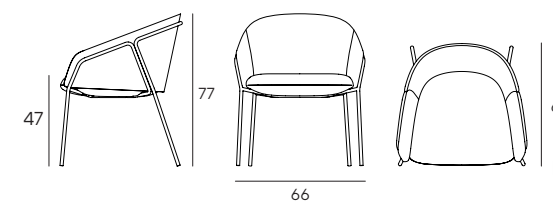

For the bases finishing, see on page 212
Per le finiture dei basamenti vedi pag. 212



look

This armchair features an open form. Broad, sharp and always inviting. Different bases and legs are available in wood and metal.

Una poltroncina con una forma aperta, ampia e netta, pronta ad accogliere, da scegliere con vari basamenti e gambe in metallo o legno.



PICTURE BASES= FROM LEFT P10- S5- R1



\DESCRIPTION

Steel framework, entirely moulded in cold-cure polyurethane.

Weight: from kg 11 to 21

Required fabric: 1,50 m. (h 1,40)

Other combinations of fabrics available on request.
*consumptions based on fabrics without pattern.

F FAMILY



L17



L3



L13



P2 (fissa/ fixed)
P10 (girevole/ swivelling)



C1



R1



R15



N1/ N1R
(with castors/ con ruote)

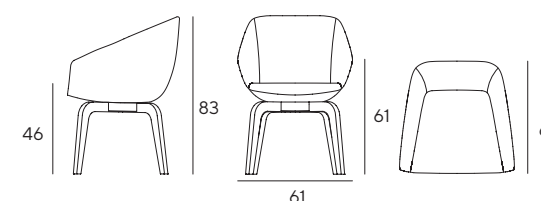

For the bases finishing, see on page 212
Per le finiture dei basamenti vedi pag. 212

diamond

The strength of this chair is its small dimensions. This easy and compact armchair is also comfortable at the dining table, without occupying too much space.

Il suo punto di forza sono le dimensioni contenute. È una poltroncina comoda e compatta così è confortevole anche al tavolo da pranzo, senza occupare troppo spazio.



PICTURE BASES= WOOD L5 - METAL R1



\DESCRIPTION

Steel framework, entirely moulded in cold-cure polyurethane.

Weight: from kg 11 to 22

Required fabric: 1,50 m. (h 1,40)

Other combinations of fabrics available on request.
*consumptions based on fabrics without pattern.

\DESCRIZIONE

Struttura della scocca in acciaio, interamente stampata in poliuretano schiumato a freddo.

Peso: da kg 11 a 22

Tessuto occorrente: 1,50 mt. (h 1,40)

Altre combinazioni di tessuti disponibili su richiesta.
*consumi calcolati con tessuti senza rapporto.



R15



L17



L7



C1



P2 (fissa/fixed)
P10 (girevole/swivelling)



L26



L3



N1/ N1R
(with castors/ con ruote)

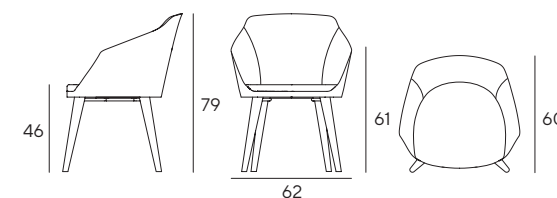

For the bases finishing, see on page 212
Per le finiture dei basamenti vedi pag. 212

bloom

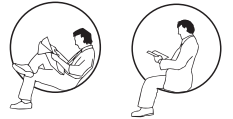

Sweet shapes that evoke comfort and light-heartedness. A soft shell supported by different bases: in wood for a warmer touch or in metal for a more decisive style.

Forme dolci che evocano comodità e spensieratezza. Un guscio morbido sostenuto dalle diverse basi: in legno per un tocco più caldo e in metallo per uno stile più deciso.

Supporting structure in rigid polyurethane with ultra soft expanded polyurethane foam.

Struttura portante in poliuretano rigido con imbottitura in poliuretano espanso ultra soft.

Weight: from kg 13 to 18
Required fabric: 1,80 m. (h 1,40)
 Other combinations of fabrics available on request.
 *consumptions based on fabrics without pattern.

Peso: da kg 13 to 18
Tessuto occorrente: 1,80 mt. (h 1,40)
 Altre combinazioni di tessuti disponibili su richiesta.
 *consumi calcolati con tessuti senza rapporto.

F FAMILY



P2 (fissa/fixed)
P10 (girevole/swivelling)

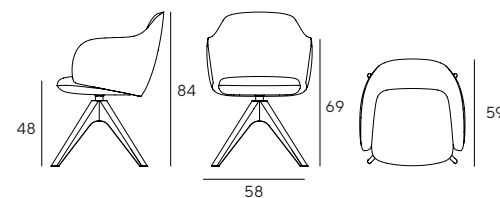

For the bases finishing, see on page 212
 Per le finiture dei basamenti vedi pag. 212



shell

The perfect solution is always at hand with Shell. Different bases and legs in wood or metal can be coupled with an infinity of fabrics that can also be paired.

Con Shell la soluzione giusta si trova sempre perché propone diversi basamenti e gambe in metallo e legno, e un'infinità di tessuti da usare anche accoppiati.



\DESCRIPTION

Steel framework, entirely moulded in cold-cure polyurethane.

Weight: from kg 9 to 14

Required fabric: 1,50 m. (h 1,40)

Other combinations of fabrics available on request.
*consumptions based on fabrics without pattern.

\DESCRIZIONE

Struttura della scocca in acciaio, interamente stampata in poliuretano schiumato a freddo.

Peso: da kg 9 a 14

Tessuto occorrente: 1,50 mt. (h 1,40)

Altre combinazioni di tessuti disponibili su richiesta.
*consumi calcolati con tessuti senza rapporto.



volume 6.0 | INNOVA

volume 6.0 | INNOVA

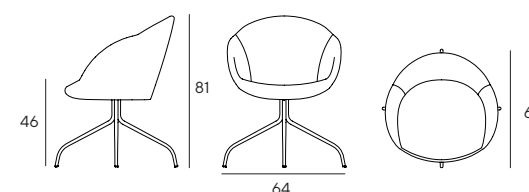

PICTURE BASES= FROM LEFT P2- P13

For the bases finishing, see on page 212
Per le finiture dei basamenti vedi pag. 212





kuma

Kuma is a smart product. Its shape is not intrusive, it is simple but with sinuous lines, perfect for any situation: from the office to a hall, or for a waiting room.

Kuma è un prodotto smart. La sua forma non è invadente, è semplice ma dalle forme sinuose, perfette per ogni situazione: dall'ufficio a una hall, o una waiting room.

\DESCRIPTION

Steel framework, entirely moulded in cold-cure polyurethane.

Weight: from kg 7 to 12

Required fabric: 1,50 m. (h 1,40)

Other combinations of fabrics available on request.

*consumptions based on fabrics without pattern.

\DESCRIZIONE

Struttura della scocca in acciaio, interamente stampata in poliuretano schiumato a freddo.

Peso: da kg 7 a 12

Tessuto occorrente: 1,50 mt. (h 1,40)

Altre combinazioni di tessuti disponibili su richiesta.

*consumi calcolati con tessuti senza rapporto.

volume 6.0 | INNOVA



volume 6.0 | INNOVA

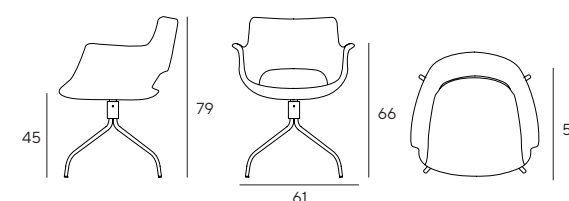

PICTURE BASE= FROM LEFT L17 - P10

For the bases finishing, see on page 212
Per le finiture dei basamenti vedi pag. 212



olie

Olie is a fun product that was born as a blank sheet... Have fun colouring it with the style and fabrics you like more.

Olie è un prodotto divertente che nasce come un foglio bianco... Divertiti tu a colorarla con lo stile ed i tessuti che più ti piacciono.



PICTURE BASES= FROM LEFT L17- R15- N1



\DESCRIPTION

Steel framework, entirely moulded in cold-cure polyurethane.

Weight: from kg 10 to 15

Required fabric: entire product 1,70 m. (h 1,40)
cushions 0,90 m. / structure 1,10 m. (h 1,40)
Other combinations of fabrics available on request.
*consumptions based on fabrics without pattern.

F FAMILY



L17



R1



P2 (fissa/ fixed)
P10 (girevole/ swivelling)



C1



R15



N1/ N1R
(with castors/ con ruote)

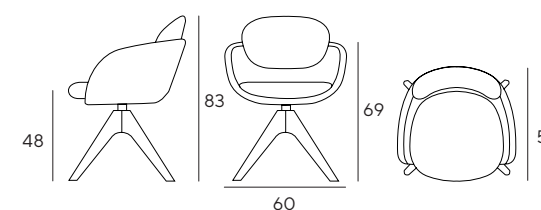

For the bases finishing, see on page 212
Per le finiture dei basamenti vedi pag. 212



olie lounge



Olie lounge version: more surface area, more comfort and more fun. Round and playful shapes that can be combined with different types of seats. Let yourself be transported into a world of fabrics, woods and colours.

Olie versione lounge: più superficie, più comfort e più divertimento. Forme tonde e giocose che possono essere abbinata a diverse tipologie di sedute. Lasciatevi trasportare in un mondo di tessuti, legni e colori.

\DESCRIPTION

Steel framework, entirely moulded in cold-cure polyurethane.

Weight: from kg 12 to 17

Required fabric: entire product 2,50 m. (h 1,40) cushions 1,10 m. / structure 1,70 m. (h 1,40)
Other combinations of fabrics available on request.
*consumptions based on fabrics without pattern.

\DESCRIZIONE

Struttura della scocca in acciaio, interamente stampata in poliuretano schiumato a freddo.

Peso: da kg 12 a 17

Tessuto occorrente: prodotto intero 2,50 mt. (h 1,40) cuscini 1,10 mt. / struttura 1,70 mt. (h 1,40)
Altre combinazioni di tessuti disponibili su richiesta.
*consumi calcolati con tessuti senza rapporto.

F FAMILY



L21



R8



R13



C1

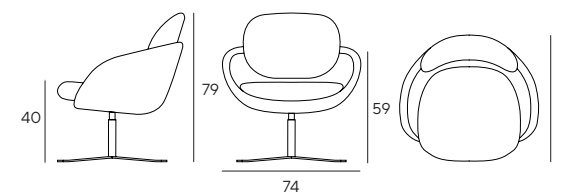

For the bases finishing, see on page 212
Per le finiture dei basamenti vedi pag. 212



— curvy

Curvy is inspired by the soft and rounded forms of the 1960s, including the elegant stitching on the back that, upon request, render the structure even more sinuous.

Curvy si ispira alle forme morbide e arrotondate degli anni sessanta, comprese le eleganti cuciture sullo schienale che, su richiesta, rendono la struttura ancora più sinuosa.



PICTURE BASES= FROM LEFT GL- L21

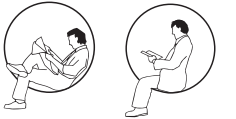

\DESCRIPTION

Steel framework, entirely moulded in cold-cure polyurethane.

Weight: from kg 17 to 30

Required fabric: 3,50 m. (h 1,40)

Other combinations of fabrics available on request.
*consumptions based on fabrics without pattern.

\DESCRIZIONE

Struttura della scocca in acciaio stampata in poliuretano schiumato a freddo.

Peso: da kg 17 a 30

Tessuto occorrente: 3,50 mt. (h 1,40)

Altre combinazioni di tessuti disponibili su richiesta.
*consumi calcolati con tessuti senza rapporto.



GL



L21



L31



R7



R13



S7

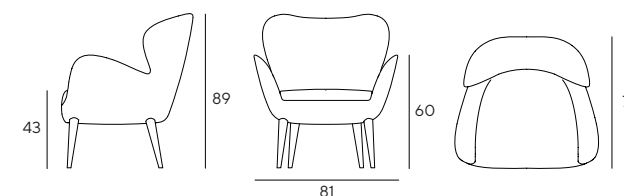

For the bases finishing, see on page 212
Per le finiture dei basamenti vedi pag. 212

hug



Hug: adaptable and expressive armchair, suggested for relax areas or waiting rooms. Different design with a wide selection of metal and wooden base.

Hug: poltroncina dalla forma stilizzata, versatile ed espressiva. Consigliata per zone relax o aree d'attesa. L'ampia scelta dei vari basamenti e delle gambe, in metallo e legno, ne caratterizza il design.

\DESCRIPTION

Steel framework, entirely moulded in cold-cure polyurethane.

Weight: armchair from kg 13 to 26, pouf from kg 6 to 15
Required fabric: armchair 3,00 m.(h 1,40)
 pouf 1,00 m. (1,40)
 Other combinations of fabrics available on request.
 *consumptions based on fabrics without pattern.

\DESCRIZIONE

Struttura della scocca in acciaio stampata in poliuretano schiumato a freddo.

Peso: poltrona da kg 13 a 26, pouf da kg 6 a 15
Tessuto occorrente: poltrona 3,00 mt. (h 1,40),
 pouf 1,00 mt. (h 1,40)
 Altre combinazioni di tessuti disponibili su richiesta.
 *consumi calcolati con tessuti senza rapporto.

volume 6.0 | INNOVA



volume 6.0 | INNOVA



L21



R13/ POUF R14



S7



R7/ POUF R8



L31 / POUF L15

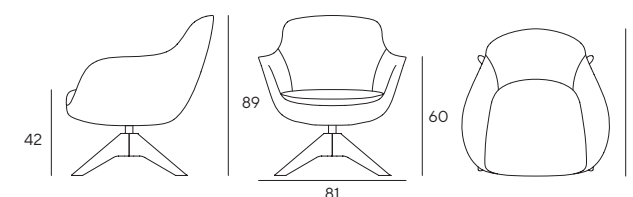

PICTURE BASES= ARMCHAIR L31- POUF L15

For the bases finishing, see on page 212
 Per le finiture dei basamenti vedi pag. 212





bloom lounge

Comfort increases in the Bloom lounge version. The backrest rises and prepares with a perfectly shaped headrest and with a cushion for an extra soft seat.

Aumenta la comodità in Bloom versione lounge. Lo schienale si alza e si prepara con un poggiatesta perfettamente conformato e un cuscino per una seduta extra morbida.



volume 6.0 | INNOVA

volume 6.0 | INNOVA

\DESCRIPTION

Supporting structure in rigid polyurethane with ultra soft expanded polyurethane foam.

Weight: from kg 21 to 25

Required fabric: 3,50 m. (h 1,40)

Other combinations of fabrics available on request.
*consumptions based on fabrics without pattern.

F FAMILY



L21



R8



C1



R13

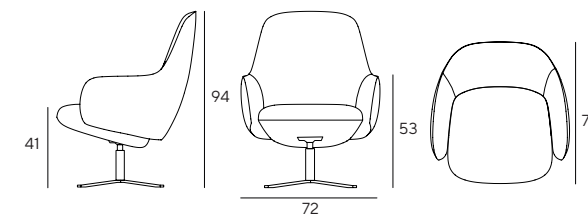

PICTURE BASES= FROM LEFT L21 - R13

For the bases finishing, see on page 212
Per le finiture dei basamenti vedi pag. 212



tera

Curved lines that meet to create chromatic contrasts or fabric harmonies, giving free rein to creativity.

Linee curve che si incontrano per creare contrasti cromatici o armonie di tessuti, dando la possibilità alla creatività di avere libero sfogo.



PICTURE BASES= P29



\DESCRIPTION

Steel framework, entirely moulded in cold-cure polyurethane.

Weight: from kg 20 to 25

Required fabric: plain colour 3,00 m. (h 1,40)
bicolor 3,50 m. (h 1,40)

Other combinations of fabrics available on request.
*consumptions based on fabrics without pattern.

\DESCRIZIONE

Struttura della scocca in acciaio, interamente stampata in poliuretano schiumato a freddo.

Peso: da kg 20 a 35

Tessuto occorrente: colore unito 3,00 mt. (h 1,40)
bicolore 3,50 mt. (h 1,40)

Altre combinazioni di tessuti disponibili su richiesta.
*consumi calcolati con tessuti senza rapporto.

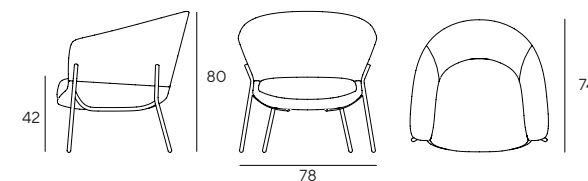

For the bases finishing, see on page 212
Per le finiture dei basamenti vedi pag. 212



noem

Simple and lively, what else? That is the life we want to. Just whistle and Noem is ready to kick, upon her tapered legs, to reach offices, hotels, domestic and contract environments.

Semplice e frizzante, come altro è la vita che vogliamo? Basta un fischio e Noem è pronta a sgambettare, su gambe sempre affusolate, verso uffici, alberghi, contesti domestici e contract.



\DESCRIPTION

Steel framework, entirely moulded in cold-cure polyurethane.

Weight: from kg 12 to 16

Required fabric: 1,80 m. (h 1,40)

Other combinations of fabrics available on request.
*consumptions based on fabrics without pattern.

\DESCRIZIONE

Struttura della scocca in acciaio, interamente stampata in poliuretano schiumato a freddo.

Peso: da kg 12 a 16

Tessuto occorrente: 1,80 mt. (h 1,40)

Altre combinazioni di tessuti disponibili su richiesta.
*consumi calcolati con tessuti senza rapporto.



volume 6.0 | INNOVA

volume 6.0 | INNOVA



L7



L26



L12



S5



C1



R1



P2 (fissa/fixed)
P10 (girevole/swivelling)



N1/ N1R
(with castors/ con ruote)

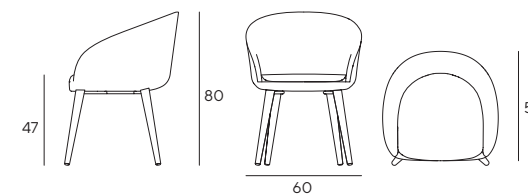

PICTURE BASES= FROM LEFT BASES L3- L17 - L12

For the bases finishing, see on page 212
Per le finiture dei basamenti vedi pag. 212

11M UNI 9175
OMOLOGATO

kat

Kat is a slight and sensitive little armchair. As its related sofa, its peculiarity is the thin structure, where the seat and the two small armrest wings lean on.

Kat è una poltroncina dall'aspetto esile e delicato. Come il divano della stessa famiglia, la sua particolarità è la struttura sottile, su cui appoggiano la seduta e le piccole ali dei braccioli.



\DESCRIPTION

The structure of the body is in solid wood and curved plywood, stained steel basament. Expanded polyurethane foam, seat in foam and dacron.

Weight: kg 18

Required fabric: 2,50 m. (h 1,40).

Other combinations of fabrics available on request. *consumptions based on fabrics without pattern.

\DESCRIZIONE

Struttura della scocca in legno massello e composito curvato, basamento in metallo verniciato. Imbottitura in poliuretano espanso a quote differenziate, sedile in gomma e dacron.

Peso: kg 18

Tessuto occorrente: 2,50 mt. (h 1,40).

Altre combinazioni di tessuti disponibili su richiesta.

*consumi calcolati con tessuti senza rapporto.

F FAMILY

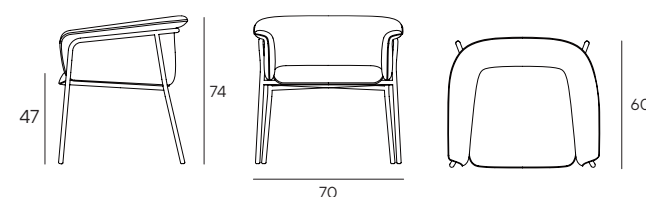

For the bases finishing, see on page 212
Per le finiture dei basamenti vedi pag. 212



little cloud

Little Cloud has an older sister, now an iconic product loved by everyone, inspired by the welcoming style of its rounded lines.

Little Cloud ha una sorella maggiore, ormai prodotto iconico amato da tutti, a cui si ispira per lo stile accogliente delle sue linee tonde.



PICTURE BASES = FROM LEFT BASES L17 - L13



\DESCRIPTION

Steel framework, entirely moulded in cold-cure polyurethane.

Weight: from kg 10 to 15

Required fabric: 1,80 m. (h 1,40)

Other combinations of fabrics available on request.
*consumptions based on fabrics without pattern.

F FAMILY



L7



L17



L13



P2 (fissa/fixed)
P10 (girevole/swivelling)



R15



R1



C1



N1/N1R
(with castors/ con ruote)

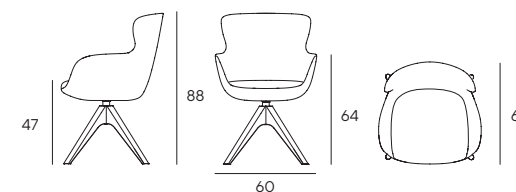

For the bases finishing, see on page 212
Per le finiture dei basamenti vedi pag. 212

cloud

An armchair with rounded and sinuous lines, to be finished with different and even contrasting fabrics and colours. Perfect at home, in a hotel or the office.

Una poltroncina dalle linee arrotondate e sinuose, da vestire anche con tessuti diversi a contrasto colore. Sa assumere uno stile domestico, alberghiero o d'ufficio.



PICTURE BASE=L32



\DESCRIPTION

Steel framework, entirely moulded in cold-cure polyurethane. Both for armchair and pouf.

Weight: armchair from kg 17 to 30, pouf from kg 6 to 15
Required fabric: armchair 3,50 m. (h 1,40)
 pouf 1,00 m. (1,40)
 Other combinations of fabrics available on request.
 *consumptions based on fabrics without pattern.

F FAMILY



L21



L14/POUF L15



R13/POUF R14



R7/POUF R8

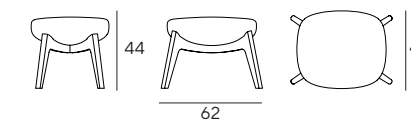
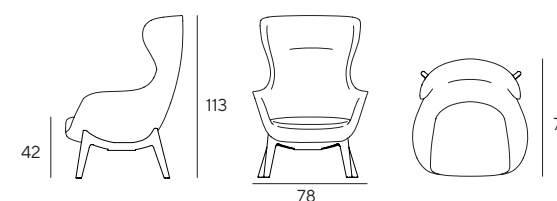

For the bases finishing, see on page 212
 Per le finiture dei basamenti vedi pag. 212



smoky low



Armchair with soft and sinuous lines. different high of the back make it suitable for various location: the office of the "boss", meeting rooms and at home, why not?.

Poltroncina dalle linee morbide e sinuose. La possibilità di avere più opzioni per l'altezza dello schienale la rende adatta ad ambienti diversi: per l'ufficio del "capo", per grandi sale riunioni e, perché no, per la casa.

\DESCRIPTION

Steel framework, entirely moulded in cold-cure polyurethane.

Weight: from kg 15 to 30

Required fabric: 2,80 m. (h 1,40)

Other combinations of fabrics available on request.
*consumptions based on fabrics without pattern.

\DESCRIZIONE

Struttura della scocca in acciaio, interamente stampata in poliuretano schiumato a freddo.

Peso: da kg 15 a 30

Tessuto occorrente: 2,80 mt. (h 1,40)

Altre combinazioni di tessuti disponibili su richiesta.
*consumi calcolati con tessuti senza rapporto.

F FAMILY



L21



L25



L31



R13



R7/POUF SKY R4



S7

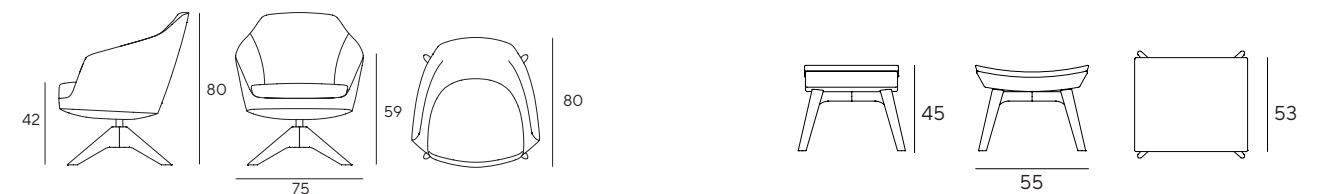

For the bases finishing, see on page 212
Per le finiture dei basamenti vedi pag. 212



PICTURE BASES= POUF L27 - ARMCHAIR L21

smoky medium



volume 6.0 | INNOVA



volume 6.0 | INNOVA

\DESCRIPTION

Steel framework, entirely moulded in cold-cure polyurethane.

Weight: from kg 18 to 30

Required fabric: 2,90 m. (h 1,40)

Other combinations of fabrics available on request.
*consumptions based on fabrics without pattern.

F FAMILY



L21



L25



L31



R13



R7/ POUF SKY R4



S7

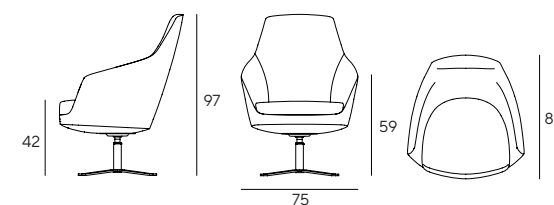

For the bases finishing, see on page 212
Per le finiture dei basamenti vedi pag. 212

smoky high



volume 6.0 | INNOVA



volume 6.0 | INNOVA

\DESCRIPTION

Steel framework, entirely moulded in cold-cure polyurethane.

Weight: from kg 18 to 30

Required fabric: 3,00 m. (h 1,40)

Other combinations of fabrics available on request.
*consumptions based on fabrics without pattern.

F FAMILY



L21



L31



L25



R13



R7/POUF SKY R4



S7

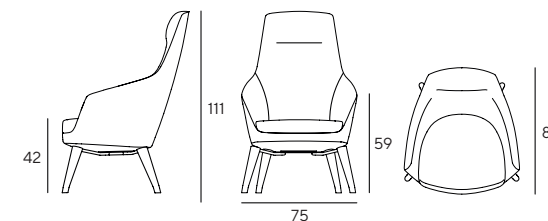

For the bases finishing, see on page 212
Per le finiture dei basamenti vedi pag. 212

11M UNI 9175
OMOLOGATO

bands bergère

Bergère reinterpretation of the namesake chair, the armchair bands has a great padding with different levels that makes it comfortable.

Reinterpretazione in chiave bergère dell'omonima sedia, la poltrona bands ha un'imbottitura a quote differenziate, che la rende comoda e confortevole.



\DESCRIPTION

Solid beech wood structure, backrest and seat in curved plywood with expanded polyurethane foam.

Weight: kg 15

Required fabric: 3,50 m. (h 1,40)

Other combinations of fabrics available on request.
*consumptions based on fabrics without pattern.

\DESCRIZIONE

Struttura della base in massello di faggio, schienale e seduta in multistrato curvato, imbottiti con poliuretano espanso a quote differenziate.

Peso: kg 15

Tessuto occorrente: 3,50 mt. (h 1,40)

Altre combinazioni di tessuti disponibili su richiesta.
*consumi calcolati con tessuti senza rapporto.

F FAMILY

POLTRONA BERGÈRE /
ARMCHAIR BERGÈRE



DONDOLO BERGÈRE /
ROCKING BERGÈRE

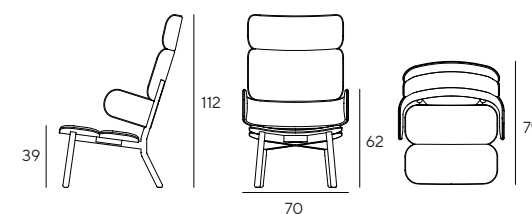

For the bases finishing, see on page 212
Per le finiture dei basamenti vedi pag. 212

 11M UNI 9175
OMOLOGATO

bands lounge

The particular seat of Bands, in its high or low version, can be combined also to the rocking base in solid beech wood.

La caratteristica seduta di Bands, in versione alta o bassa, si può abbinare anche alla base a dondolo in faggio massiccio.



volume 6.0 | INNOVA

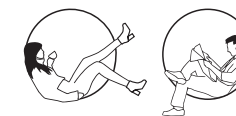

POLTRONA LOUNGE /
ARMCHAIR LOUNGE



\DESCRIPTION

Solid beech wood structure, backrest and seat in curved plywood with expanded polyurethane foam.

Weight: kg 12

Required fabric: 3,00 m. (h 1,40)

Other combinations of fabrics available on request.
*consumptions based on fabrics without pattern.

\DESCRIZIONE

Struttura della base in massello di faggio, schienale e seduta in multistrato curvato, imbottiti con poliuretano espanso a quote differenziate.

Peso: kg 12

Tessuto occorrente: 3,00 mt. (h 1,40)

Altre combinazioni di tessuti disponibili su richiesta.
*consumi calcolati con tessuti senza rapporto.

F FAMILY

DONDOLO LOUNGE /
ROCKING LOUNGE



volume 6.0 | INNOVA

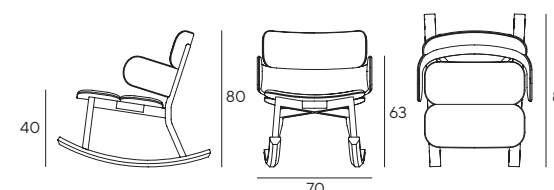

For the bases finishing, see on page 212
Per le finiture dei basamenti vedi pag. 212

11M UNI 9175
OMOLOGATO

arsenale^{GL1}

A sophisticated design and a discrete and thin structure of the backrest and armrests that encompasses the seat, encouraging conviviality and relaxation.

Un design raffinato e una struttura sottile e discreta che si fonde perfettamente con il grande cuscino di seduta morbido e accogliente.

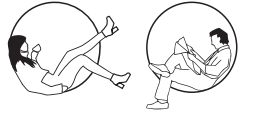

\DESCRIPTION

The structure of the body is in solid wood and curved plywood, expanded polyurethane foam, seat in foam and dacron.

Weight: kg 22

Required fabric: 2,70 m. (h 1,40)

Other combinations of fabrics available on request.
*consumptions based on fabrics without pattern.

\DESCRIZIONE

Struttura della scocca in legno massello e composito curvato, imbottitura in poliuretano espanso a quote differenziate, sedile in poliuretano e dacron.

Peso: kg 22

Tessuto occorrente: 2,70 mt.(h 1,40)

Altre combinazioni di tessuti disponibili su richiesta.
*consumi calcolati con tessuti senza rapporto.

F FAMILY

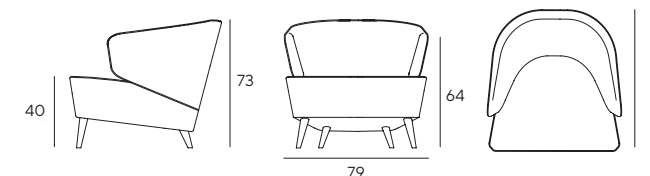

For the bases finishing, see on page 212
Per le finiture dei basamenti vedi pag. 212

 11M UNI 9175
OMOLOGATO

arsenale^{LC1}

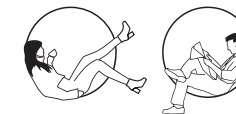

Arsenale has soft lines and a large and enveloping back.
The details of wooden basement and legs give a strong personality.

Arsenale è caratterizzata da linee morbide e da un grande e avvolgente schienale.
La particolarità del gioco d'incastro delle gambe con la seduta dà una forte personalità al prodotto.

\DESCRIPTION

The structure of the body is in solid wood and curved plywood, expanded polyurethane foam, seat in foam and dacron.

Weight: kg 22
Required fabric: 2,70 m. (h 1,40)
Other combinations of fabrics available on request.
*consumptions based on fabrics without pattern.

\DESCRIZIONE

Struttura della scocca in legno massello e composito curvato, imbottitura in poliuretano espanso a quote differenziate, sedile in poliuretano e dacron.

Peso: kg 22
Tessuto occorrente: 2,70 mt. (h 1,40),
Altre combinazioni di tessuti disponibili su richiesta.
*consumi calcolati con tessuti senza rapporto.

F FAMILY

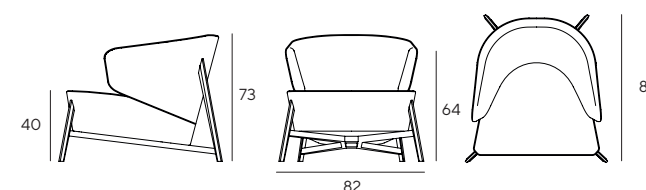

kyo

Kyo should have been a barstool with a wide seat.
But where is the ambition? And the initiative?
A crown encloses herself, since she wants more.
And she became an armchair. Royal.

Kyo poteva essere uno sgabello dall'ampia seduta.
Ma dove mettiamo l'ambizione?
E l'intraprendenza? D'una corona si cinse perché
voleva di più. E divenne poltrona. Regale.



\DESCRIPTION

The structure of the body is in solid wood and curved plywood.
Expanded polyurethane foam, seat in foam and dacron.

Weight: from kg 21 to 25
Required fabric: 3,00 m. (h 1,40)
Other combinations of fabrics available on request.
*consumptions based on fabrics without pattern.

F FAMILY



R7



L21



R13



GM1

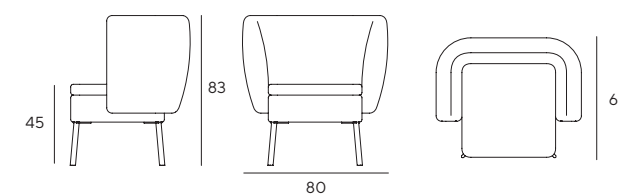

For the bases finishing, see on page 212
Per le finiture dei basamenti vedi pag. 212

\DESCRIZIONE

Struttura della scocca in legno massello e composito curvato, imbottitura in poliuretano espanso a quote differenziate, sedile in poliuretano e dacron.

Peso: da kg 21 a 25
Tessuto occorrente: 3,00 mt. (h 1,40)
Altre combinazioni di tessuti disponibili su richiesta.
*consumi calcolati con tessuti senza rapporto.



bisy

Wooden or metal base with a solid, wide and ergonomic seat.
Slope and padding of the back make Bisy inviting and comfortable.

Basamento in legno o in acciaio con una seduta compatta, ampia ed ergonomica. La leggera inclinazione e l'imbottitura sullo schienale rendono Bisy una poltroncina comoda e accogliente.



PICTURE BASE= GL2



\DESCRIPTION

The structure of the body is in solid wood and curved plywood.
Expanded polyurethane foam, seat in foam and dacron.

Weight: from kg 18 to 25
Required fabric: 3,00 m. (h 1,40)
Other combinations of fabrics available on request.
*consumptions based on fabrics without pattern.



R13



L21

\DESCRIZIONE

Struttura della scocca in legno massello e composito curvato, imbottitura in poliuretano espanso a quote differenziate, sedile in poliuretano e dacron.

Peso: da kg 18 a 25
Tessuto occorrente: 3,00 mt. (h 1,40)
Altre combinazioni di tessuti disponibili su richiesta.
*consumi calcolati con tessuti senza rapporto.

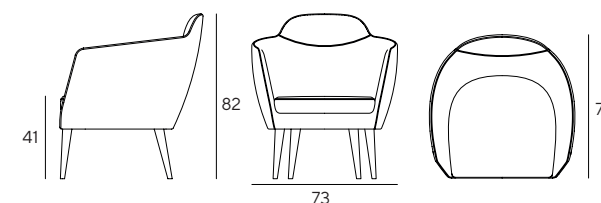

For the bases finishing, see on page 212
Per le finiture dei basamenti vedi pag. 212

look lounge



New look! It's Look Lounge. You know, you grow along with the time. What a satisfaction! It has happened also to this armchair, which is more and more comfortable, with a wider and deeper seat.

Nuovo look! È Look Lounge. Si sa, con il tempo ci si allarga un po'. Che soddisfazione! È successo anche a questa poltroncina, sempre più accogliente, con una seduta più ampia e profonda.

\DESCRIPTION

Steel framework, entirely moulded in cold-cure polyurethane.

Weight: from kg 15 to 26

Required fabric: 2,50 m. (h 1,40)

Other combinations of fabrics available on request.
*consumptions based on fabrics without pattern.

\DESCRIZIONE

Struttura della scocca in acciaio stampata in poliuretano schiumato a freddo.

Peso: da kg 15 a 26

Tessuto occorrente: 2,50 mt. (h 1,40).

Altre combinazioni di tessuti disponibili su richiesta.
*consumi calcolati con tessuti senza rapporto.



volume 6.0 | INNOVA

volume 6.0 | INNOVA



R13



L21



R7



D9



L31



S7

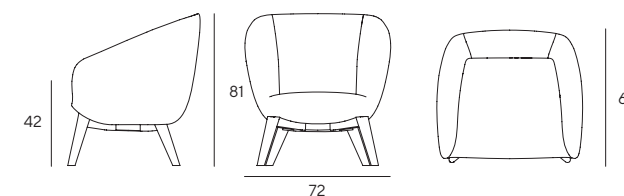

PICTURE BASE= L31

For the bases finishing, see on page 212
Per le finiture dei basamenti vedi pag. 212



adam

An elegant armchair that visually suggests an idea of comfort, thanks to the wide and wrapping backrest and to the high cushion of the seat.

Una poltrona raffinata che suggerisce anche visivamente un'idea di comodità, grazie all'ampio schienale avvolgente e al cuscino alto del sedile.



PICTURE BASE= GL



\DESCRIPTION

The structure of the body is in solid wood and curved plywood.
Expanded polyurethane foam, seat in foam and dacron.

Weight: armchair from kg 16 to 21 / pouf kg 8
Required fabric: armchair complete 2,50 m. (h 1,40)
only piping 2,50 m. (h 1,40) / pouf 1,20 m. (h 1,40)
Other combinations of fabrics available on request.
*consumptions based on fabrics without pattern.

F FAMILY



GL2

L21

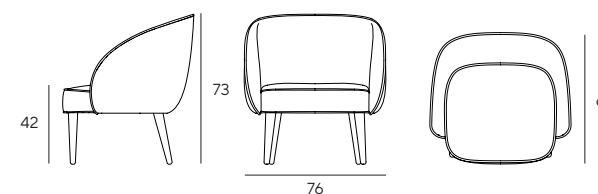

For the bases finishing, see on page 212
Per le finiture dei basamenti vedi pag. 212

\DESCRIZIONE

Struttura della scocca in legno massello e composito curvato, imbottitura in poliuretano espanso a quote differenziate, sedile in poliuretano e dacron.

Peso: poltrona da kg 16 a 21 / pouf kg 8
Tessuto occorrente: poltrona completa 2,50 mt. (h 1,40)
solo filetto 2,50 mt. (h 1,40) / pouf 1,20 mt.(h.1,40)
Altre combinazioni di tessuti disponibili su richiesta.
*consumi calcolati con tessuti senza rapporto.



adam high

It happened. Adam has grown up, and here is Adam High with an even higher and more comfortable backrest. He knows how to define a unique, private and pleasant space.

È successo. Adam si è fatto grande, ed ecco Adam High con uno schienale ancora più alto e comodo. Sa delimitare uno spazio unico, riservato e piacevole.



\DESCRIPTION

The structure of the body is in solid wood and curved plywood.
Expanded polyurethane foam, seat in foam and dacron.

Weight: kg 26,5

Required fabric: armchair complete 4,00 m. (h 1,40)
only piping 2,50 m. (h 1,40)

Other combinations of fabrics available on request.
*consumptions based on fabrics without pattern.

F FAMILY

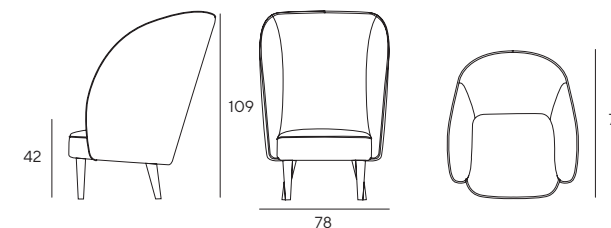

For the bases finishing, see on page 212
Per le finiture dei basamenti vedi pag. 212

\DESCRIZIONE

Struttura della scocca in legno massello e composito curvato, imbottitura in poliuretano espanso a quote differenziate, sedile in poliuretano e dacron.

Peso: kg 26,5

Tessuto occorrente: poltrona completa 4,00 mt. (h 1,40)
solo filetto mt. 2,50 (h 1,40)

Altre combinazioni di tessuti disponibili su richiesta.
*consumi calcolati con tessuti senza rapporto.

circus low

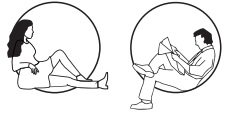

Just like the circus, the metal structure is simple. The folds of the fabric are inserted above, laid out in a harmonious way to welcome and embrace. A promise of softness.

Come al circo, la struttura in metallo è semplice. Sopra si inseriscono le volte del tessuto, tracciate in modo armonioso per accogliere e abbracciare. Una promessa di morbidezza.

\DESCRIPTION

The structure of the body is in solid wood and curved plywood, expanded polyurethane foam, seat in foam and dacron.

Weight: kg 24
Required fabric: 4,50 m. (h 1,40)
Other combinations of fabrics available on request.
*consumptions based on fabrics without pattern.

\DESCRIZIONE

Struttura della scocca in legno massello e composito curvato, imbottitura in poliuretano espanso a quote differenziate, sedile in poliuretano e dacron.

Peso: kg 24
Tessuto occorrente: 4,50 mt. (h 1,40)
Altre combinazioni di tessuti disponibili su richiesta.
*consumi calcolati con tessuti senza rapporto.

F FAMILY

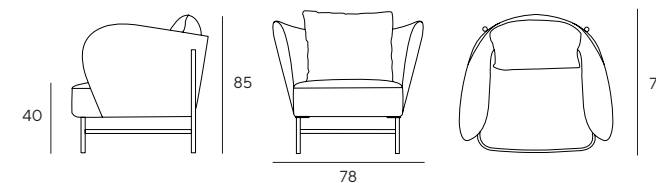

For the bases finishing, see on page 212
Per le finiture dei basamenti vedi pag. 212

11M UNI 9175
OMOLOGATO



circus high

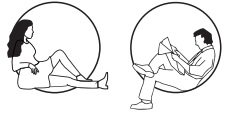

The stature of Circus high is a promise maintained, not only in its softness but also its confidentiality, with a class that is almost regal.

La stazza di Circus high è una promessa mantenuta, non solo di morbidezza ma pure di riservatezza, in una modalità di classe, quasi regale.

\DESCRIPTION

The structure of the body is in solid wood and curved plywood, expanded polyurethane foam, seat in foam and dacron.

Weight: kg 35
Required fabric: 5,00 m. (h 1,40)
Other combinations of fabrics available on request.
*consumptions based on fabrics without pattern.

\DESCRIZIONE

Struttura della scocca in legno massello e composito curvato, imbottitura in poliuretano espanso a quote differenziate, sedile in poliuretano e dacron.

Peso: kg 35
Tessuto occorrente: 5,00 mt. (h 1,40),
Altre combinazioni di tessuti disponibili su richiesta.
*consumi calcolati con tessuti senza rapporto.

F FAMILY

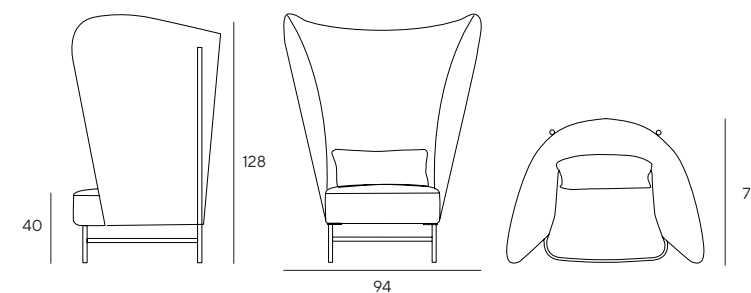

For the bases finishing, see on page 212
Per le finiture dei basamenti vedi pag. 212

11M UNI 9175
OMOLOGATO

berg low

A soft and linear armchair, as elegant and rigorous in its aesthetics as its construction, entrusted to a technology that guarantees notable comfort even in essential forms.

Una poltrona morbida e lineare, elegante e rigorosa nell'estetica quanto nella modalità costruttiva affidata a una tecnologia che garantisce comfort notevole anche a forme essenziali.



PICTURE BASES= FROM LEFT WOOD L40 - METAL P 20 WITH PADDED OPTION

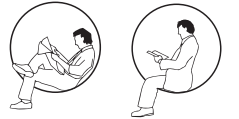

\DESCRIPTION

Structure with metal inner frame entirely moulded in cold-cure polyurethane. Seat cushion with a system **SPRING PACK**, for higher comfort.

Weight: from kg 14 to 25

Required fabric: 2,60 m. (h 1,40)

Other combinations of fabrics available on request.
*consumptions based on fabrics without pattern.

F FAMILY



L21/POUF L27



L40



R13



R7/POUF R8



R10



P20 /POUF P17

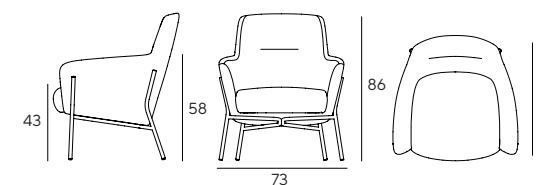

For the bases finishing, see on page 212
Per le finiture dei basamenti vedi pag. 212

berg high



Berg high is a large chair: it draws attention. It also guarantees comfort, from its reclining backrest to its soft headrest, which can be personalised in contrasting fabrics.

Berg high vanta una mole notevole: richiama l'attenzione. E garantisce comodità, dallo schienale reclinabile al morbido poggiatesta, personalizzabile con tessuto a contrasto.

\DESCRIPTION

Structure with metal inner frame entirely moulded in cold-cure polyurethane. Seat cushion with a system **SPRING PACK**, for higher comfort.
* Option WAVE SYSTEM for reclinable backrest.

Weight: armchair from kg 19 to 23, pouf from kg 7 to 9
Required fabric: complete armchair 3,20 m. (h 1,40) only headrest 0,50 m. (h 1,40) pouf m. 1,00 (h 1,40)
Other combinations of fabrics available on request.
*consumptions based on fabrics without pattern.

F FAMILY



*L 21/ POUF L27



L40



*R13/ POUF R14



*R7/ POUF R8



*R11



P20 / POUF P17

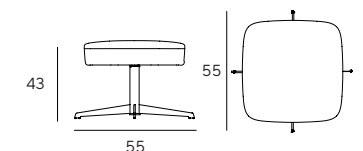
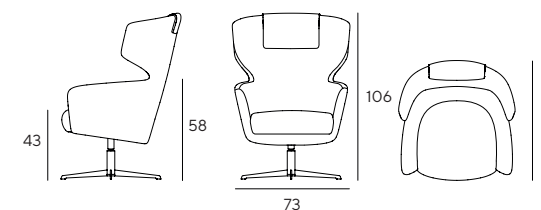

For the bases finishing, see on page 212
Per le finiture dei basamenti vedi pag. 212



nobu

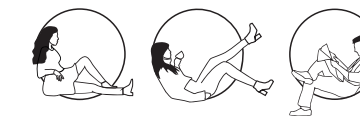

Nobu is a majestic display of fabric. It will never go unnoticed. How to ignore its soft and sinuous forms resting on its bold base? Lovely contrast. Truly unique!

Nobu è maestosa esibizione di tessuto. Di certo non passerà mai inosservata. Come ignorare le sue forme morbide e sinuose adagiate sul basamento grintoso? Bel contrasto. Unica!

\DESCRIPTION

The structure of the body is in solid wood and curved plywood, expanded polyurethane foam, seat in foam and dacron.

Weight: kg 27
Required fabric: armchair complete 5,00 m. (h 1,40) / only piping 3,00 m. (h 1,40)
 Other combinations of fabrics available on request.
 *consumptions based on fabrics without pattern.

\DESCRIZIONE

Struttura della scocca in legno massello e composito curvato, imbottitura in poliuretano espanso a quote differenziate, sedile in poliuretano e dacron.

Peso: kg 27
Tessuto occorrente: poltrona completa 5,00 mt. (h 1,40) / solo filetto 3,00 mt. (h 1,40)
 Altre combinazioni di tessuti disponibili su richiesta.
 *consumi calcolati con tessuti senza rapporto.

F FAMILY

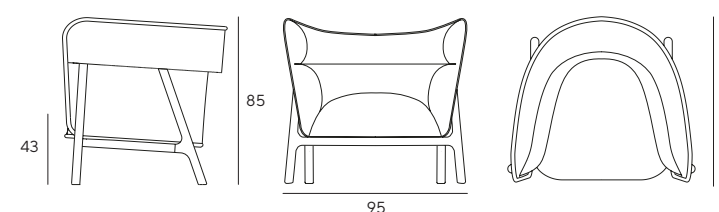

For the bases finishing, see on page 212
 Per le finiture dei basamenti vedi pag. 212



eleven



A turned wood base, balanced and elegant, with a strong character. What it supports is a seductive seat with its numerous draperies of fabric, like promised caresses.

Un basamento in legno tornito, equilibrato ed elegante, dal forte carattere. In appoggio, una seduta seducente con i suoi drappeggi a piacere di tessuto, quasi carezze promesse.

\DESCRIPTION

Steel framework, entirely moulded in cold-cure polyurethane with in addition dacron.

Weight: kg 20

Required fabric: 3,30 m. (h 1,40)

Other combinations of fabrics available on request.

*consumptions based on fabrics without pattern.

\DESCRIZIONE

Struttura della scocca in acciaio stampata in poliuretano schiumato a freddo con l'aggiunta di dacron.

Peso: kg 20

Tessuto occorrente: 3,30 mt. (h 1,40),

Altre combinazioni di tessuti disponibili su richiesta.

*consumi calcolati con tessuti senza rapporto.

F FAMILY

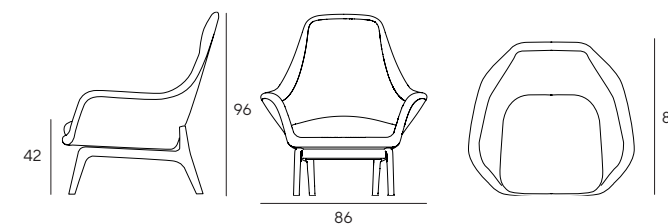

For the bases finishing, see on page 212
Per le finiture dei basamenti vedi pag. 212



otta

Otta lounge is absolute softness. A glance is enough to follow the warm invitation to sit down, whispered by the captivating contrast of fabrics and colours between the cushion and the shell.

Otta lounge è morbidezza assoluta. Basta uno sguardo per seguire il caldo invito ad accomodarsi, sussurrato dall'accattivante contrasto di tessuti e colori tra cuscino e scocca.



volume 6.0 | INNOVA

PICTURE BASES= ARMCHAIR R13 - POUF R14



\DESCRIPTION

Supporting structure in rigid polyurethane with ultra soft expanded polyurethane foam.

Weight: kg 30

Required fabric: 3,50 m. (h 1,40)

Other combinations of fabrics available on request.
*consumptions based on fabrics without pattern.

F FAMILY



R13
Pad version
Versione morbida



L21



R7
Pad version
Versione morbida

volume 6.0 | INNOVA

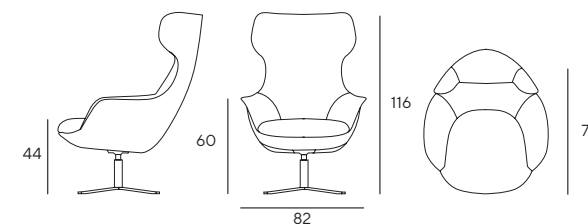

For the bases finishing, see on page 212
Per le finiture dei basamenti vedi pag. 212



mella



Mella is inspired by the soft and sinuous shapes of sweets and sugared almonds. The contained and rounded dimensions of the product make the collection adaptable to any space and context.

Mella si ispira alle forme morbide e sinuose di caramelle e confetti. Le dimensioni contenute e tonde del prodotto rendono la collezione adattabile ad ogni spazio e contesto.



volume 6.0 | INNOVA

\DESCRIPTION

The structure of the body is in solid wood and curved plywood, expanded polyurethane foam, seat in foam and dacron.

Weight: kg 18

Required fabric: plain colour 2,70 m. (h 1,40)
bicolor 3,00 m. (h 1,40)

Other combinations of fabrics available on request.
*consumptions based on fabrics without pattern.

\DESCRIZIONE

Struttura della scocca in legno massello e composito curvato, imbottitura in poliuretano espanso a quote differenziate, sedile in poliuretano e dacron.

Peso: kg 18

Tessuto occorrente: colore unito 2,70 mt. (h 1,40)
doppio colore 3,00 mt. (h 1,40)

Altre combinazioni di tessuti disponibili su richiesta.
*consumi calcolati con tessuti senza rapporto.

F FAMILY



volume 6.0 | INNOVA

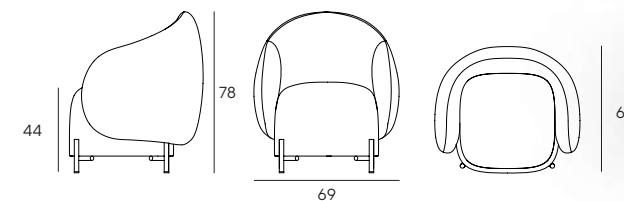

For the bases finishing, see on page 212
Per le finiture dei basamenti vedi pag. 212



**“THE JOY OF RELAXATION AND QUIET, EVERYWHERE”
“PER GODERSI RELAX E QUIETE, OVUNQUE ”**

Sofas and small sofas often furnish contract reception environments, such as waiting rooms, hotel lobbies, stations and airports, cinema and theatre foyers. In similar spaces people are looking for a comfortable seat, which shortens the distance between public and domestic space. Innova offers different solutions, **with sofas that reflect the aesthetics of our chairs and armchairs with which they can be combined, and with different proposals, to be matched in contrast**, for example a sofa with a high backrest and armrests, true walls of comfort, reflecting the most current trends.

Divani e divanetti arredano spesso gli ambienti del contract dedicati all’attesa come sale d’aspetto, hall di alberghi, stazioni e aeroporti, foyer di cinema e teatri. Qui, le persone cercano una seduta comoda e confortevole, che accorci la distanza tra ambiente pubblico e spazio domestico. Innova propone diverse soluzioni, **con divani che riprendono l’estetica delle sedie e delle poltrone con cui si combinano, e pure con proposte diverse, da abbinare a contrasto**, come il divano con schienale e braccioli alti, vere pareti di comfort, in linea con le tendenze più attuali.



kat

As the chair to which it combines, the Kat sofa has a slight and delicate structure; it has an essential architecture that kindly sustains the seat.

Come la sedia cui si abbina, il divano Kat ha una struttura esile e leggera, un'architettura essenziale che sorregge con gentilezza la seduta.



volume 6.0 | INNOVA

\DESCRIPTION

The structure of the body is in solid wood and curved plywood, stained steel basament. Expanded polyurethane foam, seat in foam and dacron.

Weight: kg 23
Required fabric: 3,50 m. (h 1,40).
Other combinations of fabrics available on request.
*consumptions based on fabrics without pattern.

\DESCRIZIONE

Struttura della scocca in legno massello e composito curvato, basamento in metallo verniciato. Imbottitura in poliuretano espanso a quote differenziate, sedile in poliuretano e dacron.

Peso: kg 23
Tessuto occorrente: 3,50 mt. (h 1,40).
Altre combinazioni di tessuti disponibili su richiesta.
*consumi calcolati con tessuti senza rapporto.

F FAMILY



volume 6.0 | INNOVA

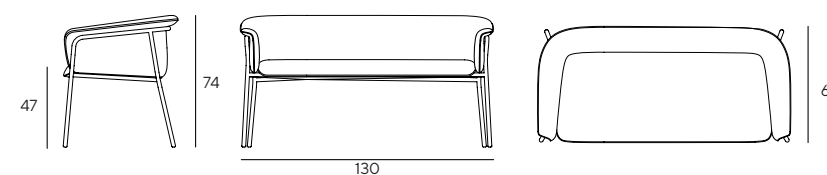

For the bases finishing, see on page 212
Per le finiture dei basamenti vedi pag. 212

11M UNI 9175
OMOLOGATO

kyo



Always more: from a king to the emperor! The Kyo's crown becomes more prestigious for the Kyo Sofa. It is perfect to isolate himself in the office, in the hall of an hotel or in the theatre foyer.

Sempre di più: da re a imperatore! La corona di cui si cinge Kyo diventa ancora più prestigiosa per Kyo Sofa. Perfetta per isolarsi in ufficio, nella hall di un albergo e nel foyer di un teatro.

volume 6.0 | INNOVA



\DESCRIPTION

The structure of the body is in solid wood and curved plywood, expanded polyutethane foam, seat in foam and dacron.

Weight: sofa low 45 kg - sofa high 55 kg

Required fabric: sofa low 5,50 m.(h 1,40)
sofa high 8,00 m. (h 1,40)

Other combinations of fabrics available on request.
*consumptions based on fabrics without pattern.

\DESCRIZIONE

Struttura della scocca in legno massello e composito curvato, imbottitura in poliuretano espanso a quote differenziate, sedile in poliuretano e dacron.

Peso: sofa basso 45 kg- sofa alto 55 kg

Tessuto occorrente: sofa basso 5,50 mt. (h 1,40)
sofa alto 8,00 mt. (1,40)

Altre combinazioni di tessuti disponibili su richiesta.
*consumi calcolati con tessuti senza rapporto.

F FAMILY



KYO SOFA LOW

volume 6.0 | INNOVA

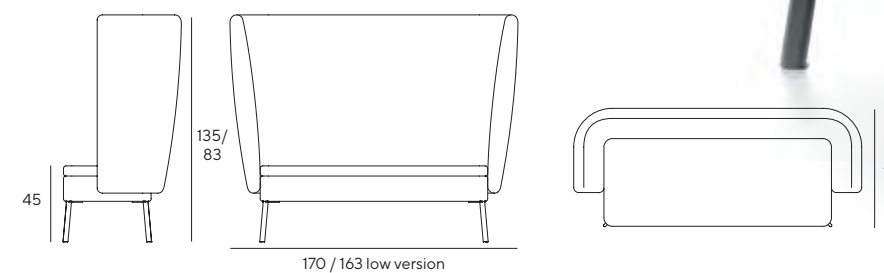

For the bases finishing, see on page 212
Per le finiture dei basamenti vedi pag. 212

11M UNI 9175
OMOLOGATO

arsenale^{GL1}

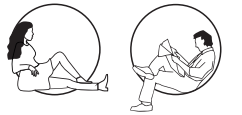

An essential sofa that combines modern forms with the contemporary taste of slow living: soft lines and sober colours give lightness and warmth to the environment.

Un divano essenziale che coniuga la modernità delle forme al gusto contemporaneo dello slow living: linee morbide e colori sobri che danno alla casa luminosità e calore.

\DESCRIPTION

The structure of the body is in solid wood and curved plywood, expanded polyurethane foam, seat in foam and dacron.

Weight: kg 38
Required fabric: 4,30 m. (h 1,40)
Other combinations of fabrics available on request.
*consumptions based on fabrics without pattern.

\DESCRIZIONE

Struttura della scocca in legno massello e composito curvato, imbottitura in poliuretano espanso a quote differenziate, sedile in poliuretano e dacron.

Peso: kg 38
Tessuto occorrente: 4,30 mt. (h 1,40)
Altre combinazioni di tessuti disponibili su richiesta.
*consumi calcolati con tessuti senza rapporto.

F FAMILY

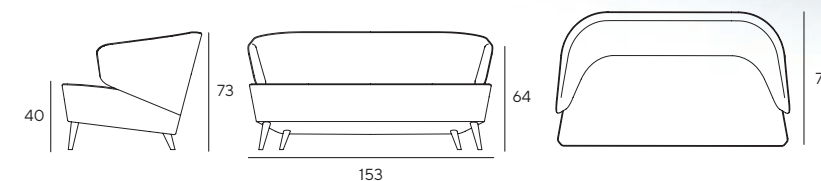

For the bases finishing, see on page 212
Per le finiture dei basamenti vedi pag. 212

I1M UNI 9175
OMOLOGATO

arsenale^{LC1}

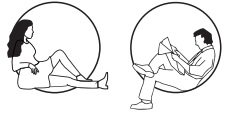

As the armchair to which it combines, the detail of the wooden basement set up with the seat gives to the Arsenale sofa a strong personality.

Come la poltroncina cui si abbina, il divano Arsenale è caratterizzato dalla particolarità del gioco d'incastro delle gambe con la seduta.

\DESCRIPTION

The structure of the body is in solid wood and curved plywood, expanded polyurethane foam, seat in foam and dacron.

Weight: sofa kg 38

Required fabric: 4,30 m. (h 1,40)

Other combinations of fabrics available on request.
*consumptions based on fabrics without pattern.

\DESCRIZIONE

Struttura della scocca in legno massello e composito curvato, imbottitura in poliuretano espanso a quote differenziate, sedile in poliuretano e dacron.

Peso: sofa kg 38

Tessuto occorrente: 4,30 mt. (h 1,40)

Altre combinazioni di tessuti disponibili su richiesta.
*consumi calcolati con tessuti senza rapporto.

F FAMILY

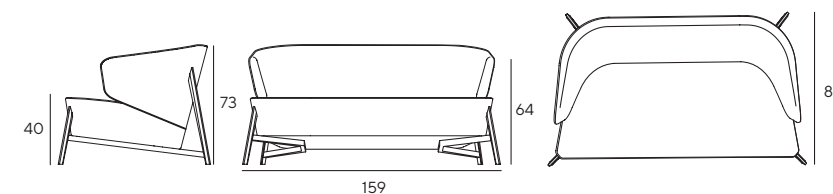

For the bases finishing, see on page 212
Per le finiture dei basamenti vedi pag. 212

11M UNI 9175
OMOLOGATO

arsenale CHAISE LONGUE



The elegance? It is the life reason for Arsenale Chaise Longue. The rest? It is his favourite hobby, which preaches everywhere. The number of his followers grows day by day.

L'eleganza? La ragione di vita di Arsenale Chaise Longue. Il riposo? La sua attività preferita, che va predicando ovunque. E di giorno in giorno cresce il numero dei suoi seguaci.



volume 6.0 | INNOVA

PICTURE BASE= LC2

\DESCRIPTION

The structure of the body is in solid wood and curved plywood, expanded polyurethane foam, seat in foam and dacron.

Weight: kg 35
Required fabric: 3,00 m. (h1,40)
 Other combinations of fabrics available on request.
 *consumptions based on fabrics without pattern.

\DESCRIZIONE

Struttura della scocca in legno massello e composito curvato, imbottitura in poliuretano espanso a quote differenziate, sedile in poliuretano e dacron.

Peso: kg 35
Tessuto occorrente: 3,00 mt. (h1,40)
 Altre combinazioni di tessuti disponibili su richiesta.
 *consumi calcolati con tessuti senza rapporto.

F FAMILY



volume 6.0 | INNOVA

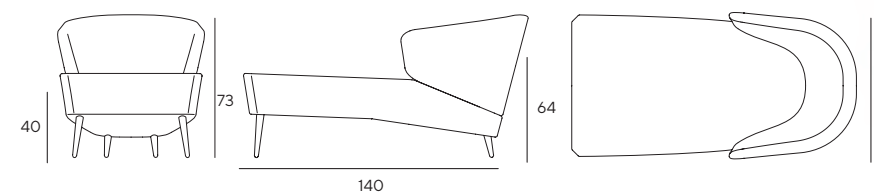

For the bases finishing, see on page 212
 Per le finiture dei basamenti vedi pag. 212



circus low

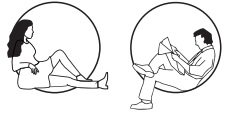

The same wrapping metal structure, but with twice the space for the sofa-version of Circus low. A softness easily inserted into a wide range of settings, with the exuberance of contrasting fabrics.

Stessa struttura avvolgente in metallo, ma spazio raddoppiato per la versione sofa di Circus Low. Una morbidezza facile da inserire nei contesti più diversi, con l'allegria dei tessuti a contrasto.

\DESCRIPTION

The structure of the body is in solid wood and curved plywood, expanded polyurethane foam, seat in foam and dacron.

Weight: kg 40
Required fabric: 7,00 m. (h 1,40)
 Other combinations of fabrics available on request.
 *consumptions based on fabrics without pattern.

\DESCRIZIONE

Struttura della scocca in legno massello e composito curvato, imbottitura in poliuretano espanso a quote differenziate, sedile in poliuretano e dacron.

Peso: kg 40
Tessuto occorrente: 7,00 mt. (h 1,40)
 Altre combinazioni di tessuti disponibili su richiesta.
 *consumi calcolati con tessuti senza rapporto.

F FAMILY

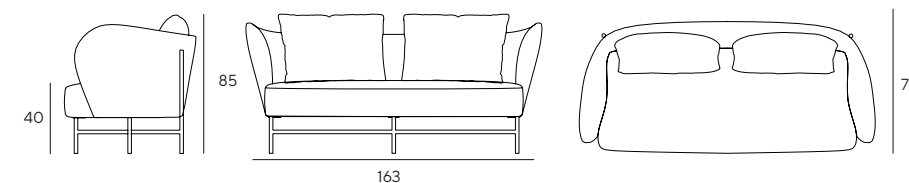

For the bases finishing, see on page 212
 Per le finiture dei basamenti vedi pag. 212

11M UNI 9175
 OMOLOGATO

circus high

Circus High continues the family tradition of the light-hearted exaggeration of the very high backrest. This creates different worlds to experience with those whose company one enjoys most.

Circus High prosegue la tradizione di famiglia dell'allegria esagerazione dello schienale, molto alto. Si creano così mondi a parte da vivere a piacere con chi ci piace di più.



\DESCRIPTION

The structure of the body is in solid wood and curved plywood, expanded polyurethane foam, seat in foam and dacron.

Weight: kg 70

Required fabric: 11,00 m. (h 1,40)

Other combinations of fabrics available on request.
*consumptions based on fabrics without pattern.

\DESCRIZIONE

Struttura della scocca in legno massello e composito curvato, imbottitura in poliuretano espanso a quote differenziate, sedile in poliuretano e dacron.

Peso: kg 70

Tessuto occorrente: 11,00 mt. (h 1,40)

Altre combinazioni di tessuti disponibili su richiesta.
*consumi calcolati con tessuti senza rapporto.

F FAMILY

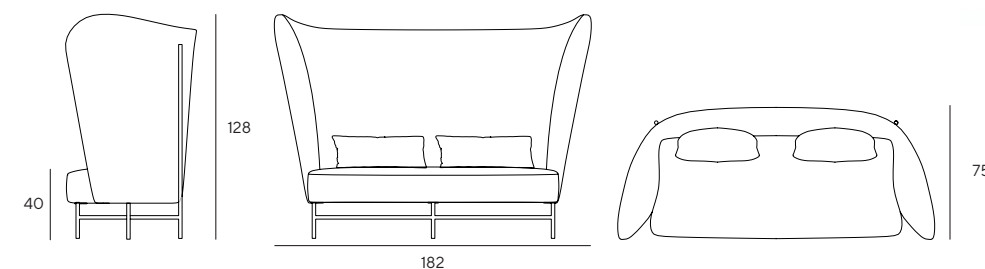

For the bases finishing, see on page 212
Per le finiture dei basamenti vedi pag. 212

adam

Adam Sofa is the most adult member of this family with its young shapes. It maintains appearances and offers two or three places, depending on the room needed on the sofa.

Adam Sofa è il rappresentante più adulto di questa famiglia dalle forme giovani. Si dà un contegno e si fa in due o tre, a seconda dei posti necessari sul divano.



volume 6.0 | INNOVA

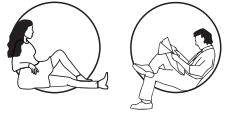

\DESCRIPTION

The structure of the body is in solid wood and curved plywood. Expanded polyurethane foam, seat in foam and dacron.

Weight: sofa 2 seaters kg 45/ sofa 3 seaters kg 50
Required fabric: sofa 2 seaters 4,30 m. (h 1,40)
 sofa 3 seaters 5,50 m. (h 1,40)
 Other combinations of fabrics available on request.
 *consumptions based on fabrics without pattern.

F FAMILY



3 SEATERS

\DESCRIZIONE

Struttura della scocca in legno massello e composito curvato, imbottitura in poliuretano espanso a quote differenziate, sedile in poliuretano e dacron

Peso: sofa 2 posti kg 45/ sofa 3 posti kg 50
Tessuto occorrente: divano 2 posti 4,30 mt. (h 1,40)
 divano 3 posti mt. 5,50(h 1,40)
 Altre combinazioni di tessuti disponibili su richiesta.
 *consumi calcolati con tessuti senza rapporto.



2 SEATERS

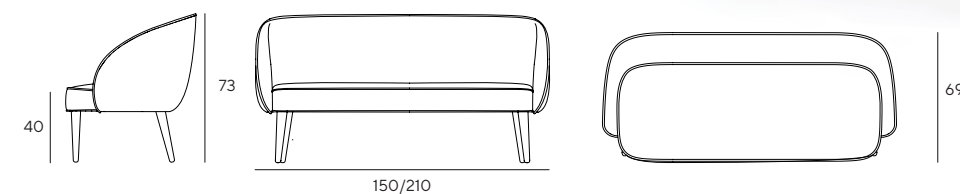

For the bases finishing, see on page 212
 Per le finiture dei basamenti vedi pag. 212



volume 6.0 | INNOVA

adam DAY BED



How much do we like? May we stay cuddle up together? Wink, Adam Day Bed. He promises unknown meeting, relaxing rest moments, chatting until the tired moon will yawn.

Quanto ci piacciamo? Stiamo vicini vicini? Strizza l'occhio, Adam Day Bed. Promette incontri imprevisi, rilassanti momenti di riposo, chiacchiere finché la luna sbadigherà esausta.

\DESCRIPTION

The structure of the body is in solid wood and curved plywood. Expanded polyurethane foam, seat in foam and dacron.

Weight: from kg 30 to 35

Required fabric: méridienne 5,50 m. (h 1,40) / vis-à-vis 5,50 m.(h 1,40) / chaise longue 4,00 m. (h 1,40)
Other combinations of fabrics available on request.
*consumptions based on fabrics without pattern.

\DESCRIZIONE

Struttura della scocca in legno massello e composito curvato, imbottitura in poliuretano espanso a quote differenziate, sedile in poliuretano e dacron

Peso: da kg 30 a 35

Tessuto occorrente: méridienne 5,50 mt.(h 1,40) / vis-à-vis 5,50 mt.(h 1,40) / chaise longue 4,00 mt. (h 1,40)
Altre combinazioni di tessuti disponibili su richiesta.
*consumi calcolati con tessuti senza rapporto.

F FAMILY



MÉRIDIANNE



CHAISE-LONGUE



VIS-À-VIS

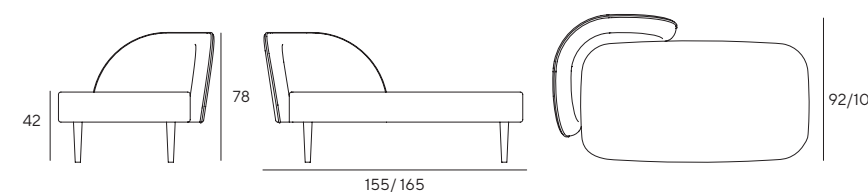

For the bases finishing, see on page 212
Per le finiture dei basamenti vedi pag. 212

IIM UNI 9175
OMOLOGATO

berg

Always larger! Berg Sofa transforms the vertical grandeur of Berg high and expands it in a further in the horizontal, with a two-seat version with different bases.

Sempre più grande! Berg Sofa trasforma l'imponenza verticale di Berg High e la espande in un ulteriore sviluppo orizzontale, versione due posti e con diversi basamenti.



\DESCRIPTION

Structure with metal inner frame entirely moulded in cold-cure polyurethane. Seat cushion with a system **SPRING PACK**, for higher comfort.

Weight: from kg 25 to 35

Required fabric: sofa complete 4,50 m. (h 1,40)
only headrests 1,00 (h 1,40)

Other combinations of fabrics available on request.
*consumptions based on fabrics without pattern.

F FAMILY



L 42



L 39



P 24



S 12

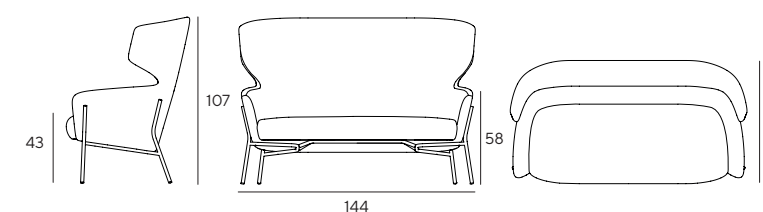

For the bases finishing, see on page 212
Per le finiture dei basamenti vedi pag. 212



brezza

The wind that caresses the sea carrying the waves gives life to Brezza. Sinuous shapes that repeat themselves, creating modular games of comfort and ethereal beauty.

Il vento che accarezza il mare trasportando le onde dà vita a Brezza. Forme sinuose che si ripetono, creando giochi componibili di comodità ed eterea bellezza.



\DESCRIPTION

The structure of the body is in solid wood and curved plywood. Expanded polyurethane foam with dacron.

Weight: single element from kg 20 to 30
Required fabric: lateral element 4,00 m. (h 1,40) / central element 3,50 m.(h 1,40) / chaise longue 5,00 m. (h 1,40)
 Other combinations of fabrics available on request.
 *consumptions based on fabrics without pattern.

\DESCRIZIONE

Struttura della scocca in legno massello e composito curvato, imbottitura in poliuretano espanso a quote differenziate con dacron.

Peso: singolo elemento da kg 20 a 30
Tessuto occorrente: elemento laterale 4,00 mt.(h 1,40) / elemento centrale 3,50 mt.(h 1,40) / chaise longue 5,00 mt. (h 1,40)
 Altre combinazioni di tessuti disponibili su richiesta.
 *consumi calcolati con tessuti senza rapporto.



volume 6.0 | INNOVA

volume 6.0 | INNOVA



ELEMENTO SINGOLO



DIVANO 2 POSTI



COMPOSIZIONE

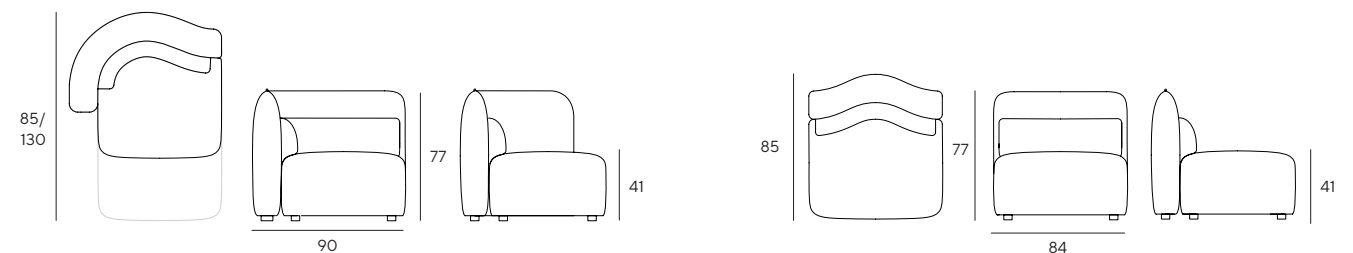

noa

Noa is like a "Tetris": a few shapes are enough to be able to create various settlements at will. The different backrests, on the other hand, create infinite comfort options

Noa è come un "Tetris": bastano poche forme per poter creare svariate composizioni a piacimento. I differenti schienali invece creano infinite opzioni di confortevolezza.

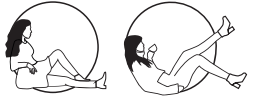

\DESCRIPTION

The structure of the body is in solid wood. Expanded polyurethane foam, seat foam and dacron.

Weight: central kg from 57 to 62, island kg 36
Required fabric: central 200 cm 6,50 m. (h 1,40)
 central 240 cm 7,50 m./ island 6,00 m. (h.1,40)
 cushion 2,00 m. each (h 1,40)
 Other combinations of fabrics available on request.
 *consumptions based on fabrics without pattern.

\DESCRIZIONE

Struttura della scocca in legno massello, imbottitura in poliuretano espanso a quote differenziate, sedile in poliuretano e dacron.

Peso: centrale da kg 57 a 62, isola kg 36
Tessuto occorrente: centrale 200 cm 6,50 m. (h 1,40)
 centrale 240 cm 7,50 m./ isola 6,00 m. (h.1,40)
 cuscini 2,00 m. cad.(h 1,40)
 Altre combinazioni di tessuti disponibili su richiesta.
 *consumi calcolati con tessuti senza rapporto.



volume 6.0 | INNOVA

volume 6.0 | INNOVA



CENTRAL



ISLAND



CENTRAL + ISLAND

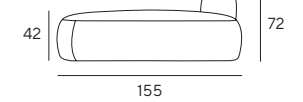
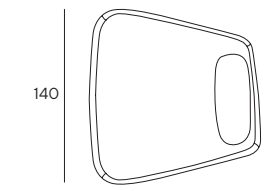
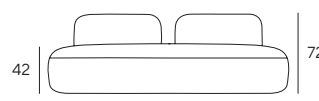
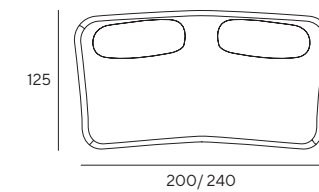

nobu

Nobu doubles its display of fabric in the sofa version, expressing more the soft shapes in contrast with the turned wooden base.

Nobu raddoppia la sua esibizione di tessuto nella versione divano, esprimendo maggiormente le forme morbide a contrasto con il basamento in legno tornito.



\DESCRIPTION

The structure of the body is in solid wood and curved plywood, expanded polyurethane foam, seat in foam and dacron.

Weight: kg 55
Required fabric: sofa complete 8,00 m. (h 1,40)
 only piping 3,00 m. (h 1,40)
 Other combinations of fabrics available on request.
 *consumptions based on fabrics without pattern.

\DESCRIZIONE

Struttura della scocca in legno massello e composito curvato, imbottitura in poliuretano espanso a quote differenziate, sedile in poliuretano e dacron.

Peso: kg 55
Tessuto occorrente: divano completa 8,00 mt. (h 1,40)/ solo filetto 3,00 mt. (h 1,40)
 Altre combinazioni di tessuti disponibili su richiesta.
 *consumi calcolati con tessuti senza rapporto.

F FAMILY



volume 6.0 | INNOVA



volume 6.0 | INNOVA

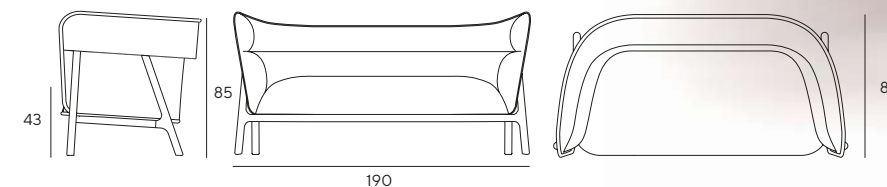

For the bases finishing, see on page 212
 Per le finiture dei basamenti vedi pag. 212

 11M UNI 9175
 OMOLOGATO

**“ADDITIONAL ELEMENTS, PASSEPARTOUT”
“QUEI COMPLEMENTI IN PIÙ, PASSEPARTOUT ”**

It's easy to call them footrests, coffee tables, even stools! Once discovered they instead become essential elements. These are the elements that resolve the most diverse situations, for their discretion and precision.
Sometimes they present an unmistakable, special style, like no other.
Other times they present simple lines to be easily combined with and support different furnishings anywhere, from bars to restaurants, from waiting rooms to the hotel reception halls, from offices to coworking stations.

Si fa presto a chiamarli pouf, tavolini, persino sgabelli! Appena scoperti diventano invece elementi essenziali. Sono quei complementi che risolvono le situazioni più diverse, discreti e precisi.
A volte hanno uno stile inconfondibile, speciale come nessun'altro,
altre scelgono linee semplici per abbinarsi con facilità ad arredi sempre diversi e sostenerli ovunque, dai bar ai ristoranti, dalle sale d'aspetto alle hall degli alberghi, dagli uffici ai coworking.



vice-versa

The Vice-versa collection says goodbye to boredom! Simple and elegant, its name is clear: direction doesn't matter, and the result will be what you want: chair, bedside table, bench, even a coworking station.

Con la collezione Vice-versa, noia addio! Semplice ed elegante, il suo nome è chiaro: non importa il verso, il risultato sarà ciò che vuoi: sedia, comodino, panca, persino stazione coworking.



\DESCRIPTION

The structure of the body is in solid wood and curved plywood with expanded polyurethane foam. The backrest and the table are in solid curved wood.

Weight: pouf kg 9 - small bench kg 14,5
big bench kg 23,5 - island kg 47 - small island 11 kg
backrest and table kg 3 each

Required fabric: pouf 1,20 m. (h 1,40) / small bench 2,20 m. (h 1,40) / big bench 2,50 m. (h 1,40)
island 3,30 m. (h,140) / small island 1,50 m. (h 1,40)
Other combinations of fabrics available on request.
*consumptions based on fabrics without pattern.

\DESCRIZIONE

Struttura della scocca in legno massello e composito curvato, imbottitura in poliuretano espanso a quote differenziate. Schienale e tavolino in legno curvato.

Peso: pouf kg 9 - small bench kg 14,5
big bench kg 23,5 - island kg 47 - small island 11 kg
schienali e tavolini kg 3 cad.

Tessuto occorrente: pouf 1,20 mt. (h 1,40) / small bench 2,20 mt. (h 1,40) / big bench 2,50 mt. (h 1,40)
island 3,30 mt. (h,140) / small island 1,50 mt. (h 1,40)
Altre combinazioni di tessuti disponibili su richiesta.
*consumi calcolati con tessuti senza rapporto.



POUF



SMALL ISLAND



SMALL BENCH



ISLAND



BIG BENCH

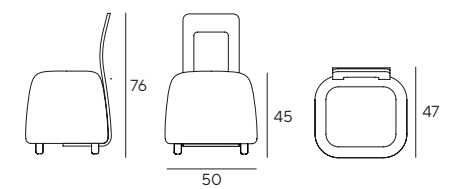
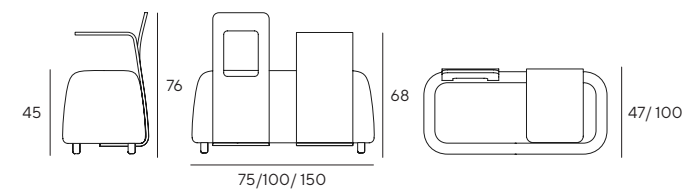

For the base, backrest and table finishing, see on page 212
Per le finiture del basamento, schienale e tavolino vedi pag. 212



vice-versa

volume 6.0 | INNOVA



\INFINITE COMPOSITIONS

POUE:

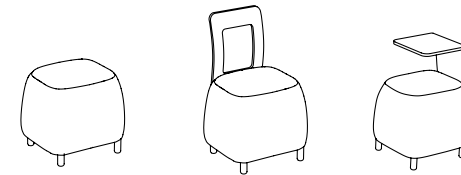

SMALL ISLAND:

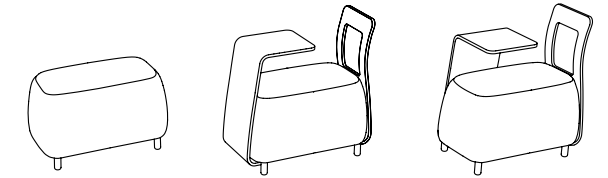

SMALL BENCH:

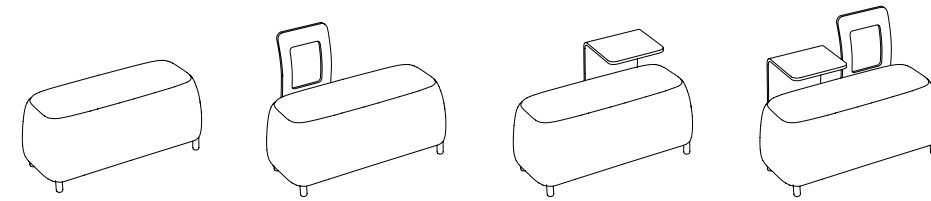

BIG BENCH:

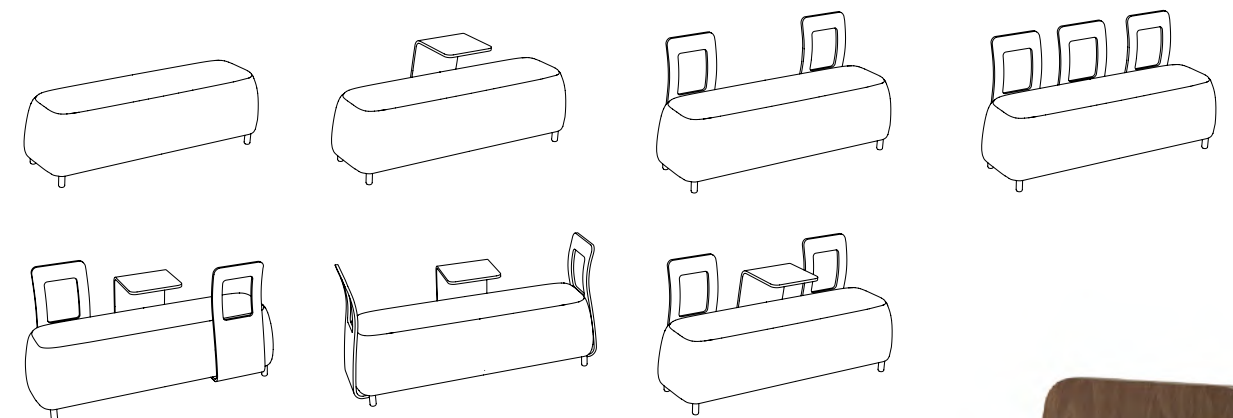

ISLAND:

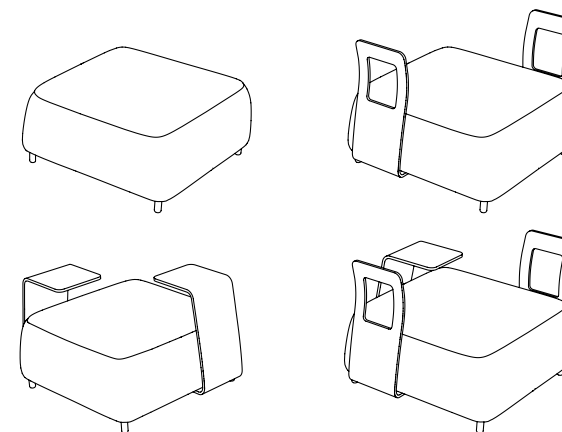

volume 6.0 | INNOVA



For the base, backrest and table finishing, see on page 212
Per le finiture del basamento, schienale e tavolino vedi pag. 212

 11M UNI 9175
OMOLOGATO

mella

Mella collection is inspired by the soft and sinuous shapes of sweets and sugared almonds. The contained and rounded dimensions of the product make the collection adaptable to any space and context.

La collezione Mella si ispira alle forme morbide e sinuose di caramelle e confetti. Le dimensioni contenute e tonde del prodotto rendono la collezione adattabile ad ogni spazio e contesto.



\DESCRIPTION

The structure of the body is in solid wood and curved plywood, expanded polyurethane foam, seat in foam and dacron. Metal varnished legs.

Weight: armchair kg 18 - small sofa kg 27- table kg 2
Required fabric: plain colour armchair 2,70 m. (h 1,40) / bicolor armchair 3,00 m. (h 1,40) / plain colour small sofa 3,50 m. (h 1,40) / bicolor small sofa 3,80 m. (h 1,40) / Other combinations of fabrics available on request.
 *consumptions based on fabrics without pattern.

\DESCRIZIONE

Struttura della scocca in legno massello e composito curvato, imbottitura in poliuretano espanso a quote differenziate, sedile in poliuretano e dacron. Gambe in metallo.

Peso: poltrona kg 18 - divano piccolo kg 27- tavolino kg 2
Tessuto occorrente: poltrona colore unito 2,70 mt. (h 1,40) / poltrona doppio colore 3,00 mt. (h 1,40) / divano piccolo colore unito 3,50 m. (h 1,40) / divano piccolo bicolor 3,80 m. (h 1,40) / Altre combinazioni di tessuti disponibili su richiesta.
 *consumi calcolati con tessuti senza rapporto.



volume 6.0 | INNOVA

volume 6.0 | INNOVA



ARMCHAIR



ARMCHAIR + TABLE



SMALL SOFA+ TABLE



SMALL SOFA

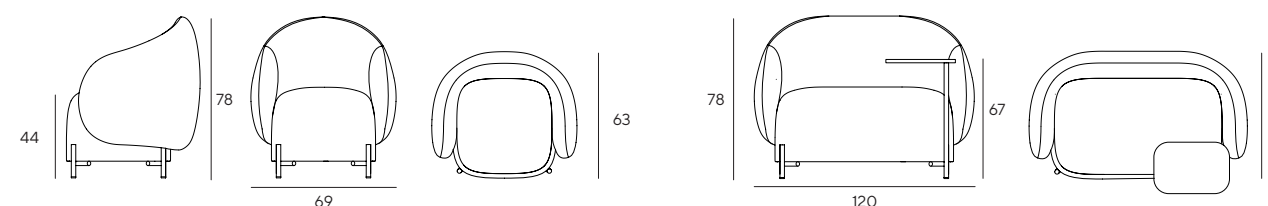

For the bases finishing, see on page 212
 Per le finiture dei basamenti vedi pag. 212



moka



They have an instantly recognisable iconic shape, and they are a concentration of energy to be exploited: pouf or coffee table, to be moved at the speed of light, wherever they are needed. This is Moka.

Hanno una forma iconica subito riconoscibile e sono un concentrato di energia da sfruttare: pouf o tavolino, da spostare alla velocità della luce, ovunque servano. Sono i Moka.



volume 6.0 | INNOVA

\DESCRIPTION

The structure of the seat is in solid wood and curved plywood with expanded polyurethane foam. The base and the table are in solid curved wood. The table has the top in porcelain stoneware or in melamine finish.

Weight: kg 8,2
Required fabric: 1,00 m. (h 1,40).
 Other combinations of fabrics available on request.
 *consumptions based on fabrics without pattern.

\DESCRIZIONE

Struttura della scocca in legno massello e composito curvato, imbottitura in poliuretano espanso a quote differenziate. Il basamento ed il tavolino sono in legno curvato. Il tavolino ha il top in grès porcellanato o con finitura in melaminico.

Peso: kg 8,2
Tessuto occorrente: 1,00 mt. (h 1,40).
 Altre combinazioni di tessuti disponibili su richiesta.
 *consumi calcolati con tessuti senza rapporto.



volume 6.0 | INNOVA

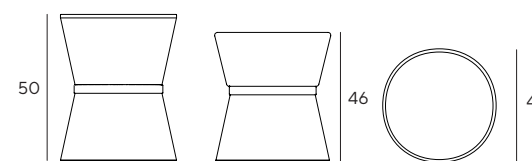

For the bases finishing, see on page 212
 Per le finiture dei basamenti vedi pag. 212

11M UNI 9175
 OMOLOGATO

ness



High or low, round or triangular, always soft at the top, with a beautiful difference in the rigor of the base. All of the Ness family are adept at multitasking: chair, table, plant holder, bag rest... The choice is yours.

Alti o bassi, tondi o triangolari, dalle forme morbide contrapposte al rigoroso basamento. I membri della famiglia Ness sono multitasking: seduta, tavolo, portapiante, poggiaborsa... Fai tu.



\DESCRIPTION

The structure of the body is in solid wood with expanded polyurethane foam. The basement in metal.

Weight: barstool kg 5,5- stool kg 3,5 - high table kg 6,5
low table kg 4,5

Required fabric: 0,70 m. (h,140)
Other combinations of fabrics available on request.
*consumptions based on fabrics without pattern.

\DESCRIZIONE

Struttura della scocca in legno massello con imbottitura in poliuretano espanso a quote differenziate. Basamento in metallo.

Peso: barstool kg 5,5- stool kg 3,5 - high table kg 6,5
low table kg 4,5

Tessuto occorrente: 0,70 mt. (h,140)
Altre combinazioni di tessuti disponibili su richiesta.
*consumi calcolati con tessuti senza rapporto.



HIGH TABLE



BARSTOOL



STOOL



LOW TABLE

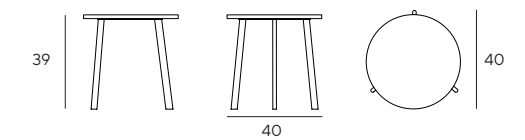
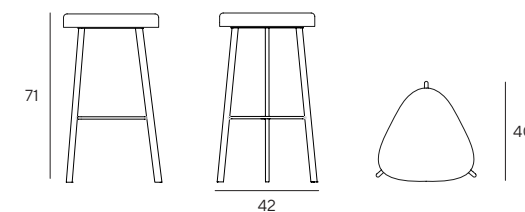

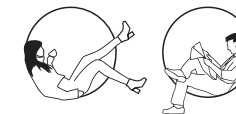

macaron

Our Macarons are as appetising as the deserts that give them their name. And just like them, one leads to another. They will never be enough to serve a space. Exquisitely tasty.

Sono appetibili come i dolcetti da cui prendono il nome, i nostri Macaron. E come loro, uno tira l'altro. Non saranno mai abbastanza per servire uno spazio. Sfiziosissimi.

\DESCRIPTION

The structure of the body is in solid wood with expanded polyutethane foam.

Weight: kg 20
Required fabric: pouf complete 3,00 m. (h 1,40) only central piping 1,20 m. (h 1,40) .
Other combinations of fabrics available on request.
*consumptions based on fabrics without pattern.

\DESCRIZIONE

Struttura della scocca in legno massello con imbottitura in poliuretano espanso a quote differenziate.

Peso: kg 20
Tessuto occorrente: pouf completo 3,00 mt. (h 1,40)/ solo filetto centrale 1,20 mt. (h 1,40)
Altre combinazioni di tessuti disponibili su richiesta.
*consumi calcolati con tessuti senza rapporto.



volume 6.0 | INNOVA

volume 6.0 | INNOVA

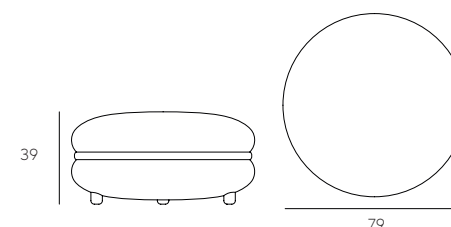

“FUNCTIONAL AND CHARACTERISING SEATING”
 “SEDUTE FUNZIONALI E CARATTERIZZANTI”

True standouts in spaces for dining and conviviality, barstools are high seats that favour a posture midway between standing and sitting. Precisely for this reason, they are **designed to be as comfortable as chairs and armchairs**, with a footrest, padded seat and wrapping backrest. Innova has created different models, also to be combined with chairs from the same family.

Immaneabili all'interno dei luoghi della ristorazione e della convivialità, gli sgabelli sono sedute alte che favoriscono una postura a metà tra lo stare in piedi e lo stare seduti. Proprio per questo sono **studiati per essere comodi al pari di sedie e poltroncine**, con poggiatesta, sedile imbottito e schienale avvolgente. Innova ha ideato modelli diversi, anche da abbinare alle sedie della stessa famiglia.



sgabby



Strong lines for a pure and essential design, to be finished with different and even contrasting fabrics and wooden colours. Perfect for different location: from home to contract.

Sgabello dalle linee decise e dal design puro ed essenziale. La possibilità di avere la struttura in legno di vari colori colloca Sgabby in diversi ambienti, dalla casa al contract.

\DESCRIPTION

Sgabby it's made with ash solid wood.

Weight: kg 5

Required fabric: 0,90 m. (h 1,40).

Other combinations of fabrics available on request.

*consumptions based on fabrics without pattern.

\DESCRIZIONE

Sgabby è disponibile in legno massello frassino.

Peso: kg 5

Tessuto occorrente: 0,90 mt. (h 1,40).

Altre combinazioni di tessuti disponibili su richiesta.

*consumi calcolati con tessuti senza rapporto.

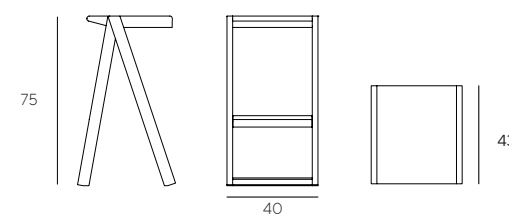

For the bases finishing, see on page 212
Per le finiture dei basamenti vedi pag. 212

11M UNI 9175
OMOLOGATO

— turtle

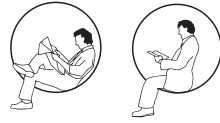

Strong and with a comfortable shell, it is the barstool for who is not in a hurry.

Ben solido e con un guscio accogliente: è lo sgabello per chi non ha fretta



volume 6.0 | INNOVA

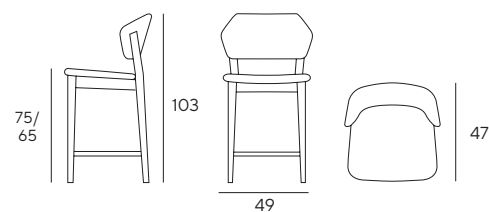

\DESCRIPTION

Weight: kg 6
Required fabric: 1,70 m. (h 1,40).
 *consumptions based on fabrics without pattern.

\DESCRIZIONE

Peso: kg 6
Tessuto occorrente: 1,70 mt. (h 1,40).
 *consumi calcolati con tessuti senza rapporto.

For the bases finishing, see on page 212
 Per le finiture dei basamenti vedi pag. 212



— ness



Ness stool, whether triangular or rounded, means comfort and simplicity.

Ness sgabello, triangolare o tondo a piacere, è comodità e semplicità.



volume 6.0 | INNOVA

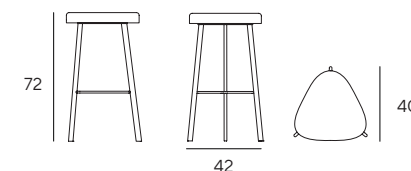

\DESCRIPTION

Weight: kg 5,5
Required fabric: 0,70 m. (h 1,40).
 *consumptions based on fabrics without pattern.

\DESCRIZIONE

Peso: kg 5,5
Tessuto occorrente: 0,70 mt.(h 1,40).
 *consumi calcolati con tessuti senza rapporto.

For the bases finishing, see on page 212
 Per le finiture dei basamenti vedi pag. 212



soho



A fresh, young and elegant stool, always ready to party.

Uno sgabello fresco, giovane ed elegante, sempre pronto a far festa.



volume 6.0 | INNOVA

\DESCRIPTION

Weight: kg 6,5
Required fabric: 1,00 m. (h 1,40).

*consumptions based on fabrics without pattern.

\DESCRIZIONE

Peso: kg 6,5
Tessuto occorrente: 1,00 mt.(h 1,40).

*consumi calcolati con tessuti senza rapporto.

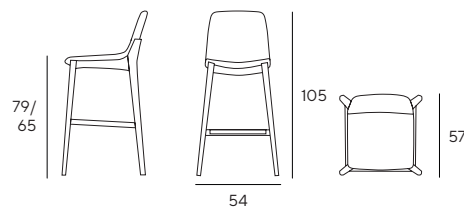

For the bases finishing, see on page 212
Per le finiture dei basamenti vedi pag. 212



rivoli



A structured and comfortable stool for a sophisticated and reserved environment.

Per un ambiente raffinato e riservato, uno sgabello strutturato e comodo.



volume 6.0 | INNOVA

\DESCRIPTION

Weight: kg 6,5
Required fabric: 1,10 m. (h 1,40).

*consumptions based on fabrics without pattern.

\DESCRIZIONE

Peso: kg 6,5
Tessuto occorrente: 1,10 mt. (h 1,40).

*consumi calcolati con tessuti senza rapporto.

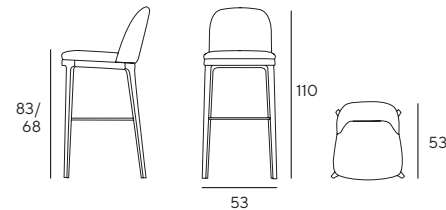

For the bases finishing, see on page 212
Per le finiture dei basamenti vedi pag. 212



look

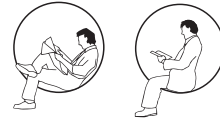

This barstool features an open form. Broad, sharp and always inviting.

Uno sgabello con una forma aperta, ampia e netta, pronta ad accogliere.



SG2



SG1

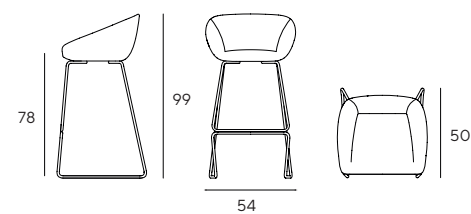

\DESCRIPTION

Weight: SG2 kg 10 - SG1 kg 21

Required fabric: 1,10 m. (h 1,40).

*consumptions based on fabrics without pattern.

\DESCRIZIONE

Peso: SG2 kg 10 - SG1 kg 21

Tessuto occorrente: 1,10 mt. (h 1,40).

*consumi calcolati con tessuti senza rapporto.

For the bases finishing, see on page 212
Per le finiture dei basamenti vedi pag. 212



wave



This barstool features a comfortable Wave-like back.

Lo sgabello Wave è caratterizzato dallo schienale a forma d'onda.



SG2



SG1

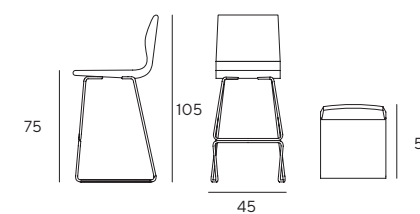

\DESCRIPTION

Weight: SG2 kg 10 - SG1 kg 21

Required fabric: 1,40 m. (h 1,40).

*consumptions based on fabrics without pattern.

\DESCRIZIONE

Peso: SG2 kg 10 - SG1 kg 21

Tessuto occorrente: 1,40 mt. (h 1,40).

*consumi calcolati con tessuti senza rapporto.

For the bases finishing, see on page 212
Per le finiture dei basamenti vedi pag. 212



izzy

With or without an opening in the back, this is the Izzy stool. Lively.

Con o senza apertura sullo schienale, lo sgabello Izzy. Frizzante.



L 48



SG2

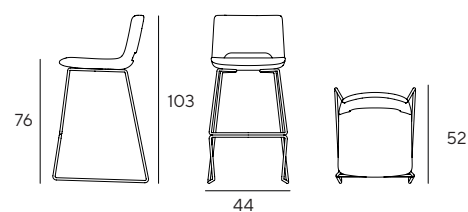

\DESCRIPTION

Weight: SG2 kg 12 - L48 kg 9

Required fabric: 1,00 m. (h 1,40).

*consumptions based on fabrics without pattern.

\DESCRIZIONE

Peso: SG2 kg 12 - L48 kg 9

Tessuto occorrente: 1,00 mt. (h 1,40).

*consumi calcolati con tessuti senza rapporto.

For the bases finishing, see on page 212
Per le finiture dei basamenti vedi pag. 212



diamond

A padded seat with precise cuts, like a diamond, but so comfortable.

Una seduta imbottita dai tagli precisi, come un diamante, tanto comoda.



L 48



SG2

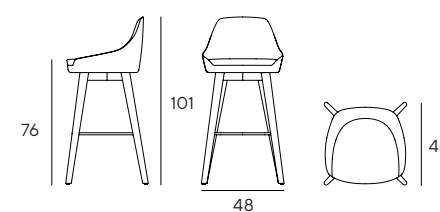

\DESCRIPTION

Weight: SG2 kg 13-L48 kg 10

Required fabric: 1,20 m. (h 1,40).

*consumptions based on fabrics without pattern.

\DESCRIZIONE

Peso: SG2 kg 13-L48 kg 10

Tessuto occorrente: 1,20 mt. (h 1,40).

*consumi calcolati con tessuti senza rapporto.

For the bases finishing, see on page 212
Per le finiture dei basamenti vedi pag. 212



**“THE SMALLEST AND MOST VERSATILE ELEMENTS”
“GLI ELEMENTI PIÙ PICCOLI E VERSATILI”**

Innova loves informal and convivial situations. This is when **poufs, cushions and coffee tables furnish spaces and offer immediate solutions, easy to move, and improvised and perfect supports.**

They shine for their versatility. Like those evenings spent with a gin and tonic in hand, vibrating to the rhythm of drum and bass while looking at the sky.

Only a few tacos for dinner late into the evening, before preparing two or three moka before heading out, walking on the clouds until a breakfast of macarons.

And then? Everything vice-versa, to start over again. First a little rest, between poufs, cushions and coffee tables.

Innova ama le situazioni informali e conviviali.

È allora che **pouf, cuscini e tavolini arredano, sono soluzioni immediate, facili da spostare, sostegni improvvisati e perfetti.**

Danno il meglio della loro versatilità. Come in quelle serate da gin and tonic in mano, a vibrare al ritmo della drum and bass guardando lo sky. Solo qualche taco sotto i denti fino a tardi, per poi preparare due-tre moka e uscire, camminando sulle cloud fino a una colazione con i macaron. E dopo? Tutto vice-versa, per ricominciare. Prima un po' di riposo, fra pouf, cuscini e tavolini.

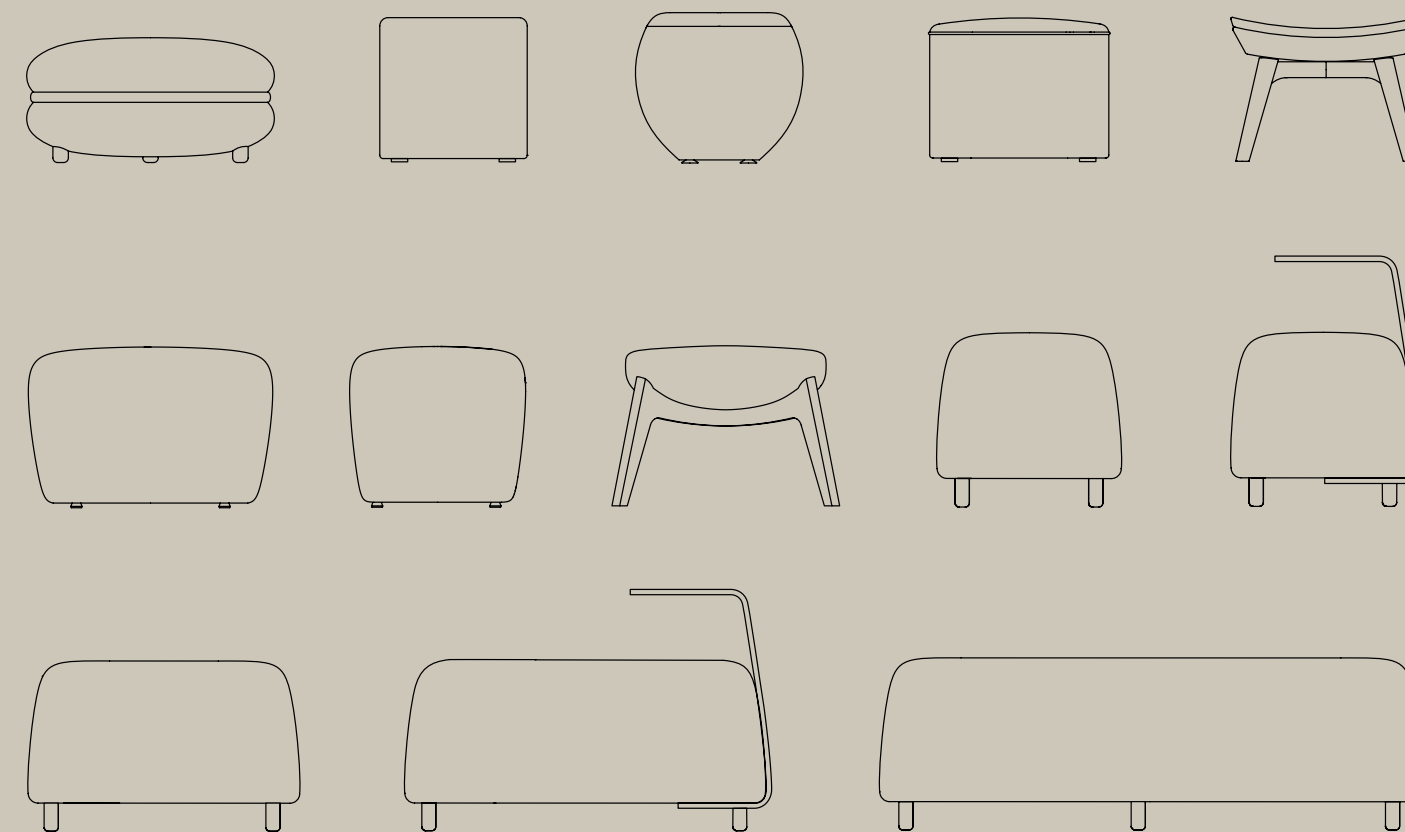

complement



pouf

Take it easy! Everything becomes easier with a smile, a little bit of play and lots of practicality. This is the lesson of our poufs. Among so many soft forms, everyone finds their own!

Take it easy! Con un sorriso, un po' di gioco e tanta praticità tutto diventa più semplice. I nostri pouf lo insegnano. Fra tante morbide forme, ognuno trova la sua!



\MACARON



Weight: 20 kg
Required fabric: pouf complete m. 3,00 (h 1,40)/ only central piping m. 1,20 (h 1,40)
 *consumptions based on fabrics without pattern.

Peso: 20 kg
Tessuto occorrente: pouf completo 3,00 mt. (h 1,40)/ solo filetto centrale 1,20 mt. (h 1,40)
 *consumi calcolati con tessuti senza rapporto.

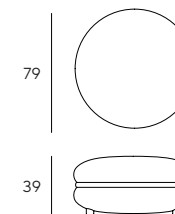

\GIN



Weight: 8 kg
Required fabric: 1,50 m. (1,40)
 *consumptions based on fabrics without pattern.

Peso: 8 kg
Tessuto occorrente: 1,50 mt. (h 1,40)
 *consumi calcolati con tessuti senza rapporto.

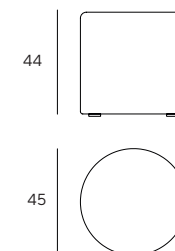

\TONIC



Weight: 8 kg
Required fabric: 1,50 m. (1,40)
 *consumptions based on fabrics without pattern.

Peso: 8 kg
Tessuto occorrente: 1,50 mt. (h 1,40)
 *consumi calcolati con tessuti senza rapporto.

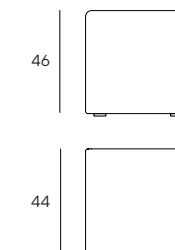



\DRUM

Weight: 9 kg
Required fabric: 1,30 m. (1,40)
 *consumptions based on fabrics without pattern.

Peso: 9 kg
Tessuto occorrente: 1,30 mt. (h 1,40).
 *consumi calcolati con tessuti senza rapporto.

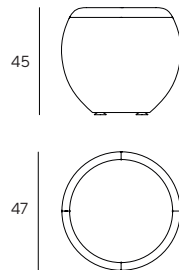

L27

\SKY

Weight: from 6 to 15 kg
Required fabric: 1,00 m. (1,40)
 *consumptions based on fabrics without pattern.

Peso: da 6 a 15 kg
Tessuto occorrente: 1,00 mt. (h 1,40).
 *consumi calcolati con tessuti senza rapporto.

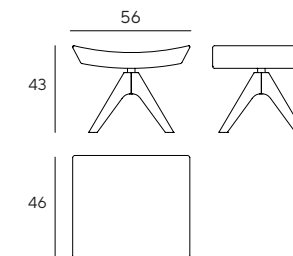

\TACO

Weight: 6 kg
Required fabric: 2,00 m. (1,40)
 *consumptions based on fabrics without pattern.

Peso: 6 kg
Tessuto occorrente: 2,00 mt.(h 1,40)
 *consumi calcolati con tessuti senza rapporto.

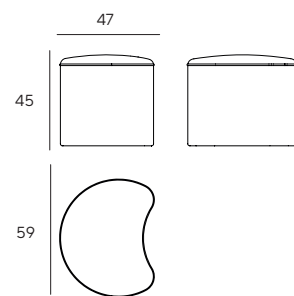

R8

\BERG

Weight: from 5 to 10 kg
Required fabric: 1,00 m. (1,40)
 *consumptions based on fabrics without pattern.

Peso: da 5 a 10 kg
Tessuto occorrente: 1,00 mt. (h 1,40)
 *consumi calcolati con tessuti senza rapporto.

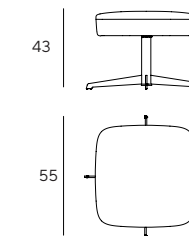

\ADAM

Weight: 8 kg
Required fabric: 1,20 m. (1,40)
 *consumptions based on fabrics without pattern.

Peso: 8 kg
Tessuto occorrente: 1,20 mt. (h 1,40).
 *consumi calcolati con tessuti senza rapporto.

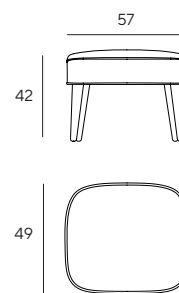

R8

\CLOUD

Weight: from 6 to 15 kg
Required fabric: 1,00 m. (1,40)
 *consumptions based on fabrics without pattern.

Peso: da 6 a 15 kg
Tessuto occorrente: 1,00 mt.(h 1,40)
 *consumi calcolati con tessuti senza rapporto.

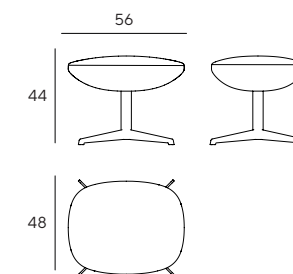



\VICE-VERSA

pouf

Weight: 9 kg
Fabric for upholstery: m. 1,20 (1,40)
 *consumptions based on fabrics without pattern.

Peso: 9 kg
Tessuto occorrente: 1,20 mt. (h 1,40).
 *consumi calcolati con tessuti senza rapporto.

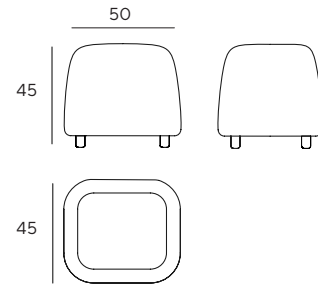

\VICE-VERSA

big bench

Weight: 23,5 kg
Required fabric: 2,50 m. (1,40)
 *consumptions based on fabrics without pattern.

Peso: 23,5 kg
Tessuto occorrente: 2,50 mt. (h 1,40).
 *consumi calcolati con tessuti senza rapporto.

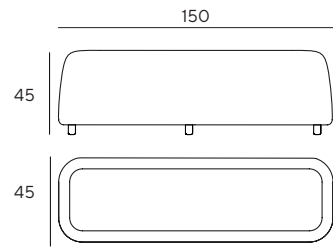

\VICE-VERSA

small island

Weight: 11 kg
Required fabric: 1,50 m. (1,40)
 *consumptions based on fabrics without pattern.

Peso: 11 kg
Tessuto occorrente: 1,50 mt. (h 1,40).
 *consumi calcolati con tessuti senza rapporto.

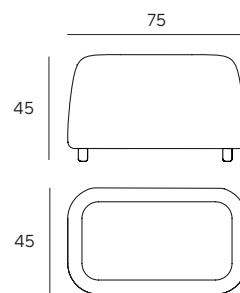

\VICE-VERSA

island

Weight: 47 kg
Required fabric: 3,30 m. (1,40)
 *consumptions based on fabrics without pattern.

Peso: 47 kg
Tessuto occorrente: 3,30 mt. (h 1,40).
 *consumi calcolati con tessuti senza rapporto.

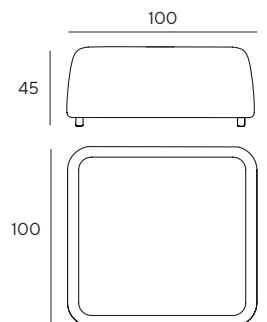

\VICE-VERSA

small bench

Weight: 14,5 kg
Required fabric: 2,20 m. (1,40)
 *consumptions based on fabrics without pattern.

Peso: 14,5 kg
Tessuto occorrente: 2,20 mt. (h 1,40).
 *consumi calcolati con tessuti senza rapporto.

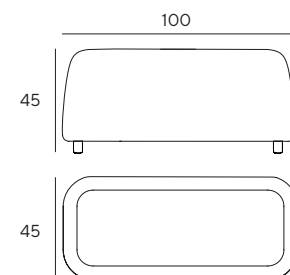

\MOKA

Weight: 8 kg
Required fabric: 1,00 m. (1,40)
 *consumptions based on fabrics without pattern.

Peso: 8 kg
Tessuto occorrente: 1,00 mt. (h 1,40).
 *consumi calcolati con tessuti senza rapporto.

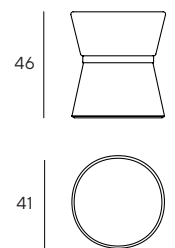



\ NEEP

small pouf

Weight: 8 kg
Required fabric: 1,30 m. (1,40)
 *consumptions based on fabrics without pattern.

Peso: 8 kg
Tessuto occorrente: 1,30 mt. (h 1,40).
 *consumi calcolati con tessuti senza rapporto.

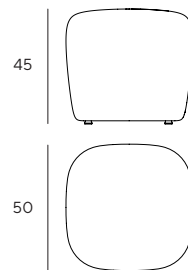

\ NOOP

big pouf

Weight: 12 kg
Required fabric: 1,60 m. (1,40)
 *consumptions based on fabrics without pattern.

Peso: 12 kg
Tessuto occorrente: 1,60 mt. (h 1,40).
 *consumi calcolati con tessuti senza rapporto.

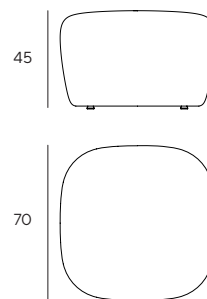

\ NESS

Weight: 3,5 kg
Required fabric: 0,70 m. (1,40)
 *consumptions based on fabrics without pattern.

Peso: 3,5 kg
Tessuto occorrente: 0,70 mt. (h 1,40).
 *consumi calcolati con tessuti senza rapporto.

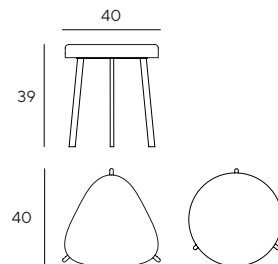

cushions



\ BASIC

Padded with dacron multifibre (available with feather on request). Evergreen that stands out products and that enhances fabrics. Piping optional.

Prodotto realizzato con imbottiture in dacron multifibre (disponibile anche in piuma su richiesta). Piping opzionale. Semplice evergreen che contraddistingue i prodotti ed esalta i tessuti.

1A > 40x40
 1B > 50x50
 1C > 60x60

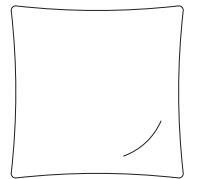

\ BIG VOLANT

Padded with dacron multifibre (available with feather on request). 5 cm flange with matching or contrast stitching on the edge that gives it a rock look!

Prodotto realizzato con imbottiture in dacron multifibre (disponibile anche in piuma su richiesta). Volant di 5 cm con cucitura a contrasto o in tinta che ne esalta il suo aspetto rock!

2A > 40x40
 2B > 50x50
 2C > 60x60

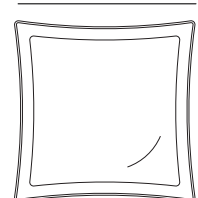

\ SMALL VOLANT

Padded with dacron multifibre (available with feather on request). The pinched stitching of 1 cm is its particularity. It can be used as decorative item or to make more comfortable the sitting.

Prodotto realizzato con imbottiture in dacron multifibre (disponibile anche in piuma su richiesta). Particolare la sua cucitura pizzicata da 1 cm. Da usare come decorazione o per rendere più confortevole la seduta.

3A > 30x60
 3B > 30x50
 3C > 20x40

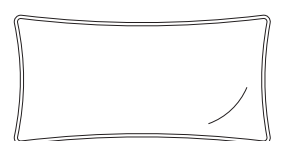

tables

A support for wine glasses, mugs, books, bags, feet... Round, square, triangular, rectangular, hexagonal and different heights. Alone or in groups, tables always help.

Un appoggio per calici, tazzine, libri, borse, piedi... Una forma tonda, quadrata, triangolare, rettangolare, esagonale e altezze diverse. Singoli o a gruppetti, i tavolini aiutano sempre.

moka

Did someone say coffee table?
Who better than Moka? Energy to exploit.

Qualcuno ha detto tavolino da caffè?
Chi meglio di Moka? Energia da sfruttare.



volume 6.0 | INNOVA

volume 6.0 | INNOVA

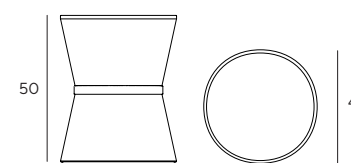

\DESCRIPTION

Weight: 10 kg
Dimensions: d. 41 cm h. 50 cm

\DESCRIZIONE

Peso: 10 kg
Dimensioni: d. 41 cm h. 50 cm

For the tables finishing, see on page 212
Per le finiture dei tavolini vedi pag. 212

— tube

A play of round and elegant tubes supporting the top, available in different finishes.

È un gioco di tubi rotondi ed eleganti che sostengono il piano, in diverse finiture.

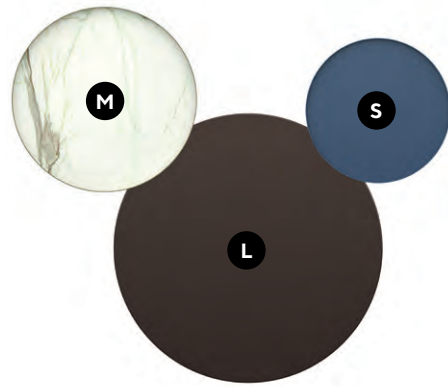

\DESCRIPTION

Weight: S 7 kg / M 9 kg / L 15 kg
Dimensions: S d. 43 h. 46 cm
 M d. 55 h. 40 cm / L d. 80 h. 35 cm

\DESCRIZIONE

Peso: S 7 kg / M 9 kg / L 15 kg
Dimensioni: S d. 43 h. 46 cm
 M d. 55 h. 40 cm / L d. 80 h. 35 cm

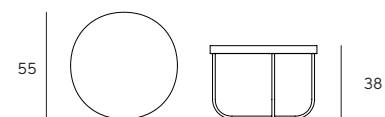

For the tables finishing, see on page 212
 Per le finiture dei tavolini vedi pag. 212

— tulu

A linear and rigorous tubular base that rises up to support the top.

Un basamento lineare e rigoroso in tondino che sale a sostenere il piano.

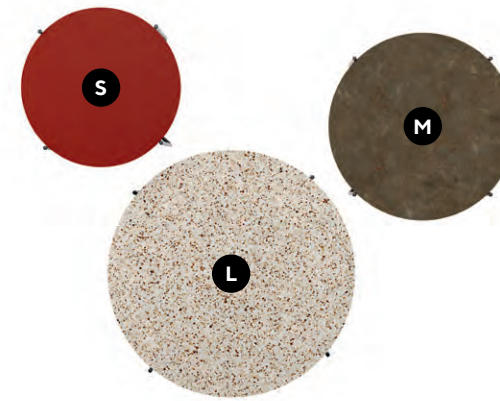

\DESCRIPTION

Weight: S 5 kg / M 7 kg / L 10 kg
Dimensions: S d. 50 cm h. 45 cm
 M d. 60 cm h. 35 cm / L d. 80 cm h. 30 cm

\DESCRIZIONE

Peso: S 5 kg / M 7 kg / L 10 kg
Dimensioni: S d. 50 cm h. 45 cm
 M d. 60 cm h. 35 cm / L d. 80 cm h. 30 cm

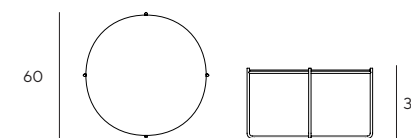

For the tables finishing, see on page 212
 Per le finiture dei tavolini vedi pag. 212

levante

A refined play between the arch that rises up and the cut of the horizontal line of the top.

Raffinato gioco tra l'arco che si leva e il taglio della linea orizzontale del piano.

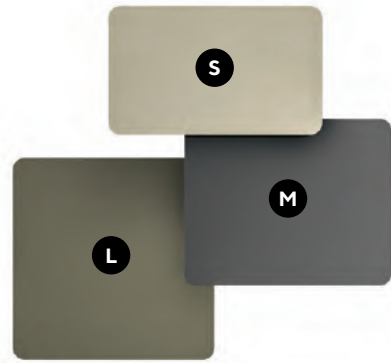

\DESCRIPTION

Weight: S 9 kg / M 9,5 kg / L 10 kg
Dimensions: S d. 50 x 30 h. 50 cm
 M d. 50 x 40 h. 40 cm / L p. 50 x 50 h. 30 cm

\DESCRIZIONE

Peso: S 9 kg / M 9,5 kg / L 10 kg
Dimensioni: S d. 50 x 30 h. 50 cm
 M d. 50 x 40 h. 40 cm / L p. 50 x 50 h. 30 cm

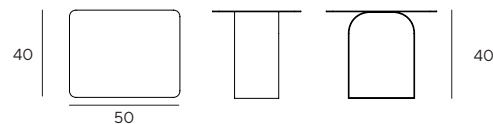

For the tables finishing, see on page 212
 Per le finiture dei tavolini vedi pag. 212

rosie

Rosie means to intersect two different souls within the same product, as the creative soul of an artist is enclosed in his person.

Rosie è intersecare due anime diverse all'interno di uno stesso prodotto, come l'anima creativa di un artista si racchiude nella sua persona.



\DESCRIPTION

Weight: M 13 kg / L 19 kg
Dimensions: M 68x 68 cm- h. 44 cm
 L 88 x 88 cm - h. 34 cm

\DESCRIZIONE

Peso: M 13 kg / L 19 kg
Dimensioni: M 68 x 68 cm- h. 44 cm
 L 88 x 88 cm - h. 34 cm

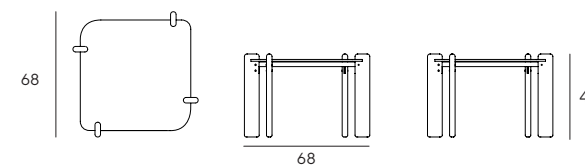

For the tables finishing, see on page 212
 Per le finiture dei tavolini vedi pag. 212

gio

Gio is a majestic but elegant presence, which embraces and softly supports its precious top.

Gio è una presenza imponente ma elegante, che abbraccia e sorregge con morbidezza il suo prezioso piano.

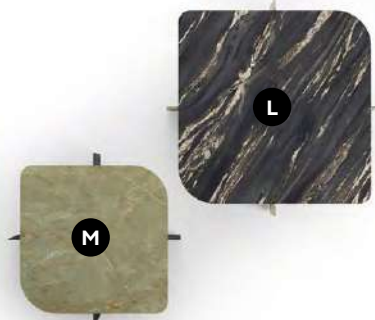

volume 6.0 | INNOVA

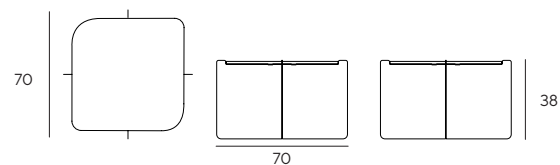

For the tables finishing, see on page 212
Per le finiture dei tavolini vedi pag. 212

gio

Gio is multitasking: with the round shape it became young, playfull and smart instead with the porcelain stoneware it is elegant and charming.

Gio è un prodotto poliedrico: con il piano tondo diventa giovanile, giocoso e smart mentre con il piano in gres è elegante e accattivante.

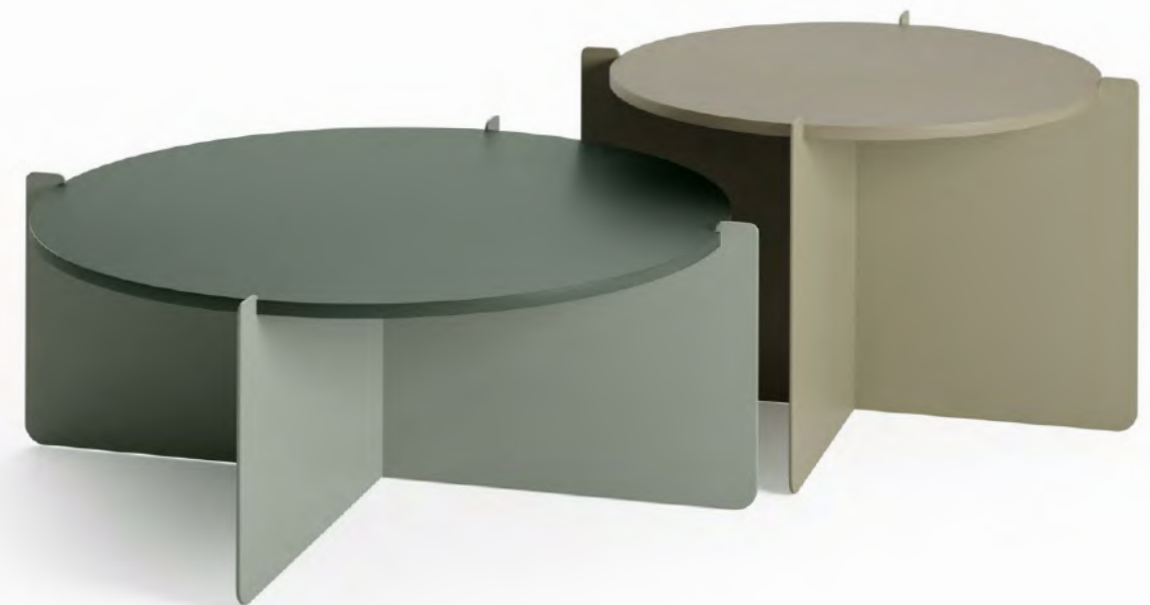
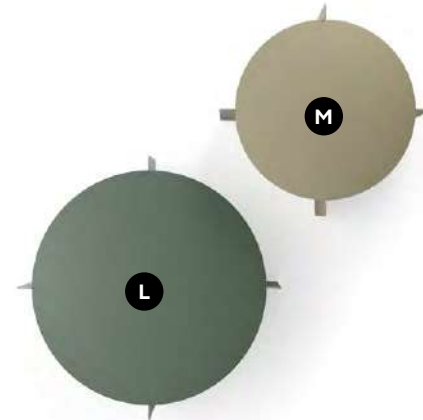

volume 6.0 | INNOVA

\DESCRIPTION

Weight: M 25 kg /L 30 kg
Dimensions: M 70 x 70 cm h. 38 cm
L 90 x 90 h. 30 cm

\DESCRIZIONE

Peso: M 25 kg /L 30 kg
Dimensioni: M 70 x 70 cm h. 38 cm
L 90 x 90 h. 30 cm

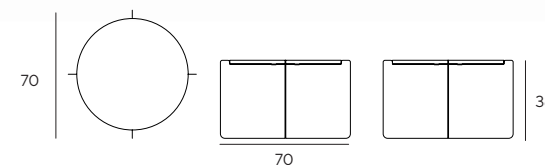

For the tables finishing, see on page 212
Per le finiture dei tavolini vedi pag. 212

layers

Alone, but above all in groups, to create plays of heights, tops, finishes and shapes.

Singoli ma soprattutto in gruppo per creare giochi di altezze, piani, finiture e forme.



volume 6.0 | INNOVA



\DESCRIPTION

Weight: S 10 kg /M 12 kg /L 15 kg
Dimensions: S d. 60 h. 49 cm
 /M d. 60 h. 40 cm /L d. 80 h. 30 cm

\DESCRIZIONE

Peso: S 10 kg /M 12 kg /L 15 kg
Dimensioni: S d. 60 h. 49 cm
 /M d. 60 h. 40 cm /L d. 80 h. 30 cm

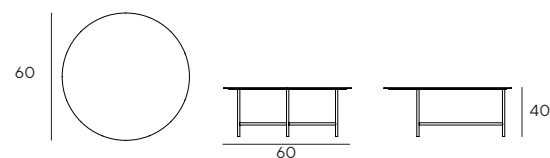

For the tables finishing, see on page 212
 Per le finiture dei tavolini vedi pag. 212

ness

Small or large, round or triangular, high or low, Ness coffee tables are as you wish them to be.

Piccoli o grandi, tondi o triangolari, alti o bassi, i tavolini Ness son come li vuoi tu.

volume 6.0 | INNOVA



\DESCRIPTION

Weight: S 4 kg /M 6,5 kg
Dimensions: S d. 40 cm h. 39 cm
 M d. 42 cm h. 68 cm

\DESCRIZIONE

Peso: S 4 kg /M 6,5 kg
Dimensioni: S d. 40 cm h. 39 cm
 M d. 42 cm h. 68 cm

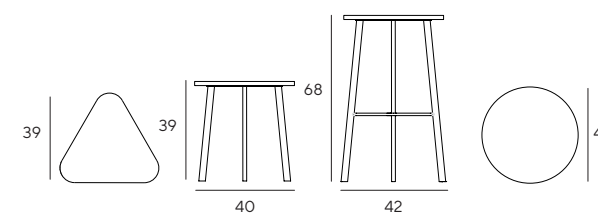

For the tables finishing, see on page 212
 Per le finiture dei tavolini vedi pag. 212

tala

Tala is a play of lines and circles that create a timeless sandglass, as a reminder that in certain situations there is no need to measure the time.

Tala è giochi di linee e cerchi che creano una clessidra senza tempo, a ricordare che in certe situazioni non c'è bisogno di misurarlo.



volume 6.0 | INNOVA

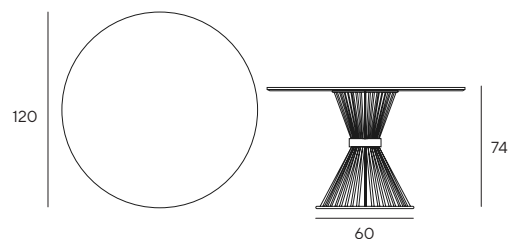

\DESCRIPTION

Weight: 60 kg
Dimensions: d. 60 h. 74 cm

\DESCRIZIONE

Peso: 60 kg
Dimensioni: d. 120 h. 74 cm

For the tables finishing, see on page 212
Per le finiture dei tavolini vedi pag. 212

INNOVA

in partnership
with

Kymo®

carpets

“WITH THE RIGHT PARTNER ALL CHALLENGES
CAN BE OVERCOME”
“CON IL PARTNER GIUSTO OGNI SFIDA PUO' ESSERE
SUPERATA”

Growing, Exploring and Innovating: this is our nature and for this reason, we wanted to get closer to a world similar to our reality and made of interweaving filaments, in order to maintain a common thread with who we are. We relied on the experience of those who have been professionals in this sector for more than 17 years to develop our design. **Kymo believed in us and shared this journey together as a partner.**

Crescere, Esplorare ed Innovare è nella nostra natura e per questo, mantenendo un filo conduttore con ciò che siamo, abbiamo voluto avvicinarci ad un mondo noi affine fatto di intrecci di filamenti. Per sviluppare il nostro design ci siamo appoggiati all'esperienza di chi è professionista nel settore da più di 17 anni. **Kymo ha creduto in noi e ha convisio questo percorso assieme come partner.**

airy

kymo
GERMANY

Two lovers between lights and shadows, like the sun with the moon... get lost in the shades of Airy!

Due amanti tra luci e ombre come il sole con la luna... perditi nelle sfumature di Airy!

volume 6.0 | INNOVA



\DESCRIPTION

Weight: 20 kg
Dimensions: d. 250 cm
Composition: 100 % polyester

\DESCRIZIONE

Peso: 20 kg
Dimensioni: d. 250 cm
Composizione: 100% poliestere

dori

kymo
GERMANY

The carefree way of mixing shapes, finishes and materials creates a bold design, free from any conventional form.

La spensieratezza nel mescolare forme, finiture e materiali crea un design audace, libero da ogni forma convenzionale.

volume 6.0 | INNOVA



\DESCRIPTION

Weight: 25 kg
Dimensions: 200 x 300 cm
Composition: 100 % wool

\DESCRIZIONE

Peso: 25 kg
Dimensioni: 200 x 300 cm
Composizione: 100% lana

“ AN UNIQUE STYLE FOR DIFFERENT ELEMENTS,
EASILY TO BE COMBINED TOGETHER.”
“UN UNICO STILE PER ELEMENTI DIVERSI,
FACILI DA ABBINARE.”

From the Innova family other families come out. They are the ones of our items, which live together harmoniously. It is a **suggestion to furnish well-adjusted spaces, where the same lines and the same rhythm are used.** Of course, it is just a suggestion: even the contrasting choices have their own reason. They create confusion or simply movement, such as when a new member arrive in the family and bring new strengths with him.

Dalla famiglia di Innova scaturiscono nuove famiglie. Sono quelle dei nostri prodotti che vivono in armonia fra loro. È **una proposta per arredare ambienti equilibrati, che rincorrono lo stesso tipo di linee e di ritmo.** Naturalmente è solo una proposta: anche le scelte a contrasto hanno il loro “perché”. Creano scompiglio o semplice movimento, come quando in famiglia arriva un nuovo membro e porta nuove forze

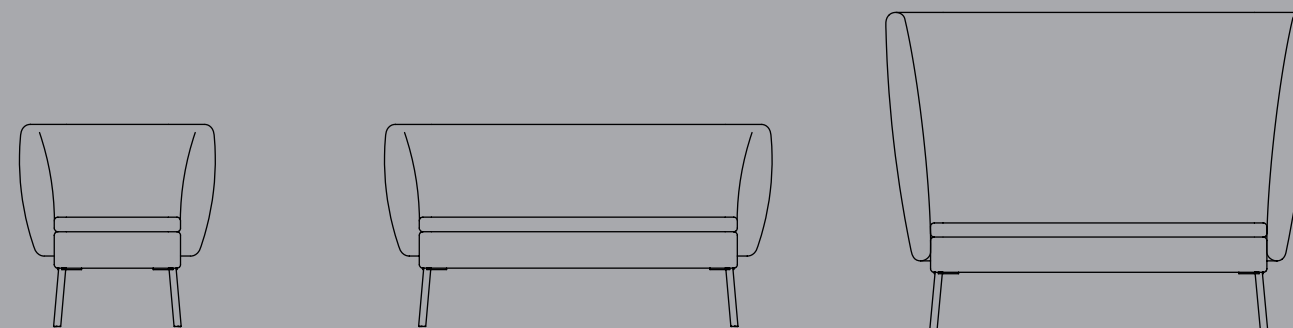
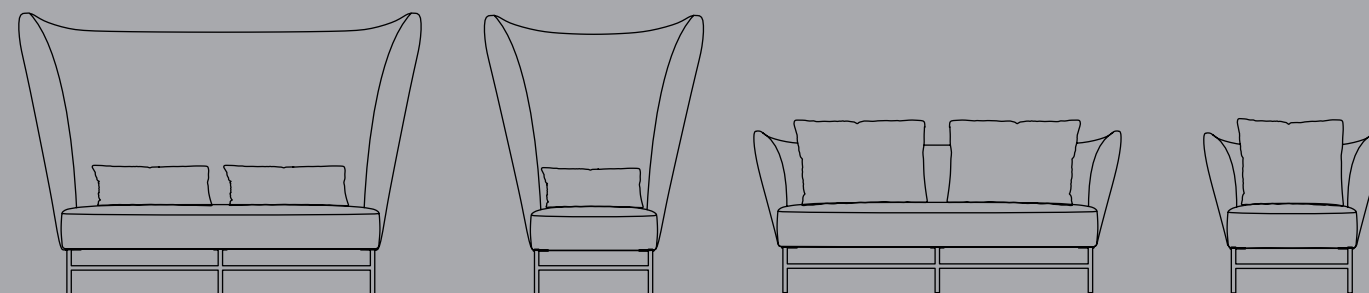

families

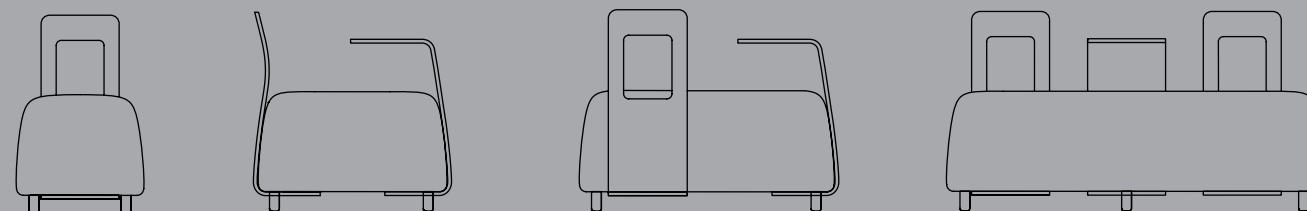
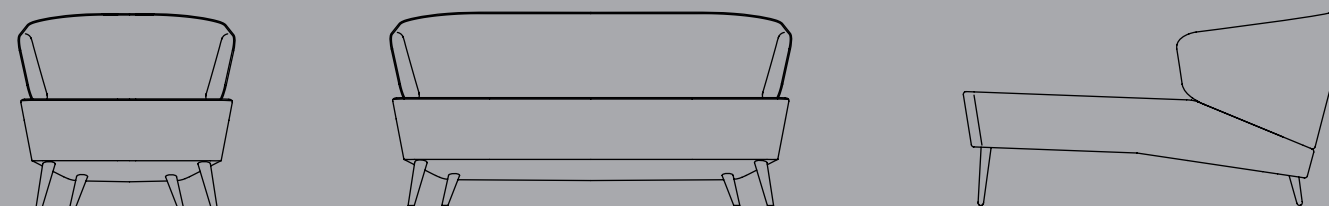
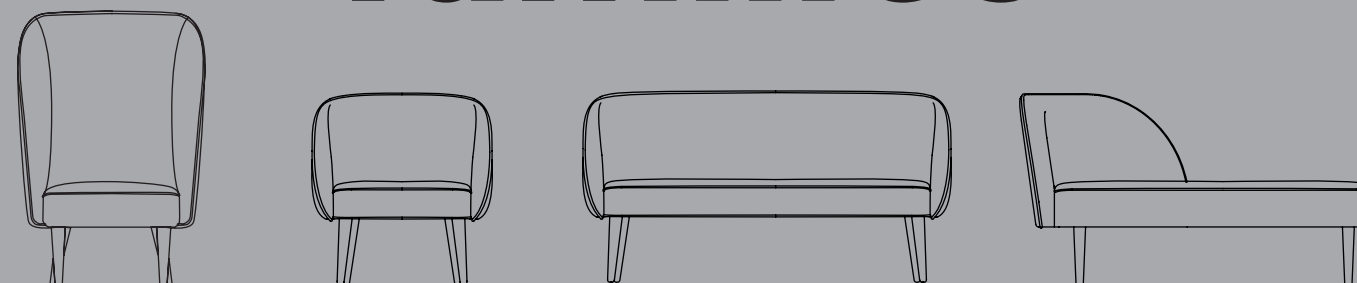

adam



arsenale



bands



berg



bloom



circus



cloud



diamond



eleven



izzy



kat



kyo



look



mella



nobu



olie



rivoli



soho



turtle



vice-versa



finishing

finishing / finiture

WOOD STANDARD FINISHING / FINITURE LEGNO STANDARD



NATURAL/
NATURALE



NATURAL OAK/
ROVERE NATURALE



WENGÉ



BLACK/
NERO



MEDIUM WALNUT/
NOCE MEDIO



CANALETTO WALNUT/
NOCE CANALETTO



DARK WALNUT/
NOCE SCURO

volume 6.0 | INNOVA

METAL STANDARD FINISHING / FINITURE METALLO STANDARD



CHROME/
CROMO



BLACK/
NERO

RAL COLOURS / COLORI RAL



BLUE

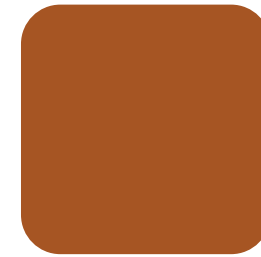

RUST

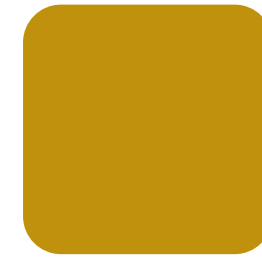

MUSTARD

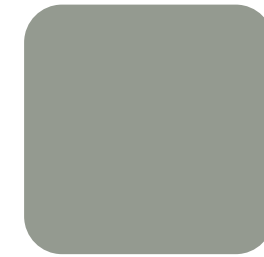

OLIVE



GREY BEIGE



GREY MILK



GREY SHADE

volume 6.0 | INNOVA

SPECIAL FINISHING / FINITURE SPECIALI



ASPHALT



CHAMPAGNE

**TABLES FINISHING /
FINITURE TAVOLINI**

**PORCELAIN STONEWARE /
GRÉS PORCELLANATO**

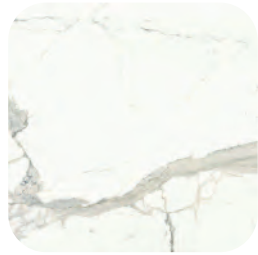

WHITE CALACATTA/
BIANCO CALACATTA



CALACATTA VECCHIA
MACCHIA



GREY MARBLE/
MARMO GRIGIO



BLACK MARQUINIA/
NERO MARQUINIA



SODALITE BLUE



CANALETTO

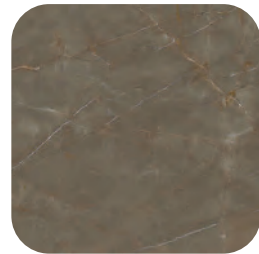

PULPIS BRONZE

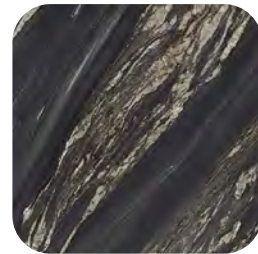

TROPICAL BLACK/
NERO TROPICALE

**TABLES MELAMINE FINISHING /
FINITURE IN MELAMINICO TAVOLINI**

**STONES AND RESINS /
PIETRE E RESINE**

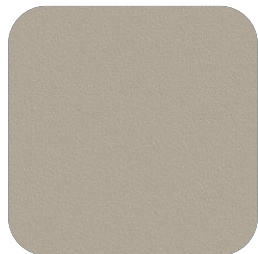

BEIGE CEMENT/
CEMENTO BEIGE



OXIDE BRONZE/
OSSIDO BRONZO

**TABLES MELAMINE COLOURS /
COLORI MELAMINICI TAVOLINI**

**SOLID COLOURS /
TINTE UNITE**

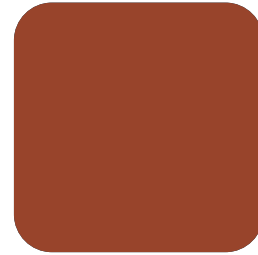

CERAMIC RED

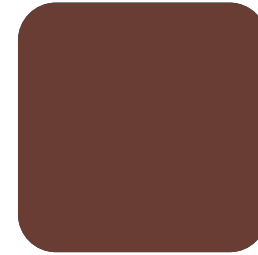

ACAI BROWN



OLIVE GREEN

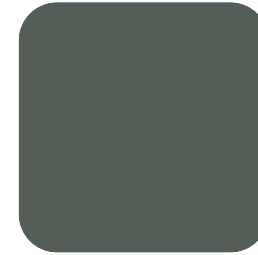

GREEN



GRAPHITE BLUE

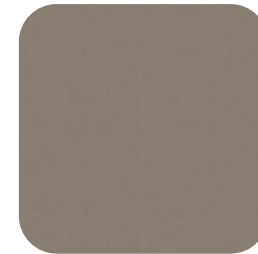

TAUPE



DARK BROWN

**TABLES MELAMINE FINISHING /
FINITURE IN MELAMINICO TAVOLINI**

**ENDGRANI WOOD /
EFFETTO LEGNO**



CLASSIC OAK/
QUERCIA CLASSIC



TAUPE OAK/
QUERCIA TAUPE

**“ THE IDEA ABOVE ALL ELSE”
“L’IDEA PRIMA DI TUTTO”**

If you like what you have seen up to here, you have appreciated a mix of ideas, work, passion and concepts to which many people have contributed.

Because ideas and people come first, before any action of marketing and communication.

The idea precedes even those who thought it up. And when it impresses, it becomes objectively interesting, regardless of where it came from.

For this reason, we decided to de-personalise our designers and represent them in a cartoon graphic, since the ideas are more important than the names – familiar or not – of their designers.

Se quello che hai visto fino a qua ti è piaciuto, hai apprezzato un mix di idee, lavoro, passione e concetti al quale hanno contribuito svariate persone.

Perché le idee e le persone vengono prima, prima di ogni azione di marketing e di comunicazione.

L’idea precede, addirittura, chi l’ha pensata. E se colpisce, diventa oggettivamente interessante, a prescindere da chi l’abbia avuta.

Per questo motivo abbiamo deciso di depersonalizzare i designer e rappresentarli in maniera graficamente cartonata poiché le idee sono più importanti del nome, conosciuto o meno, del loro designer.

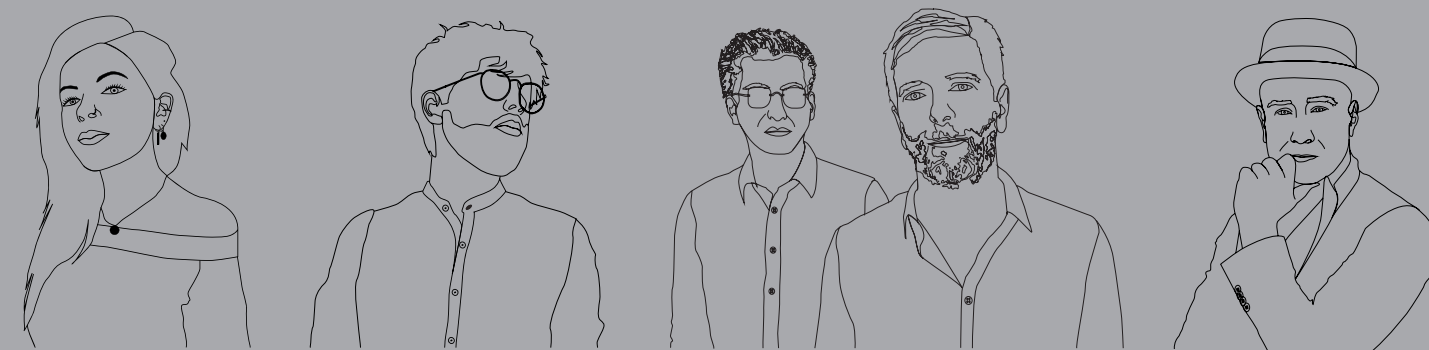

/ the designers

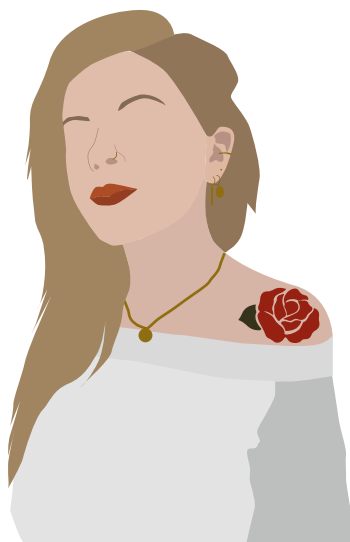

Eleonora Barillari

Art director

After graduating in 2018 from the Italian Design School in Padua, she immediately dedicated herself to furniture design using a people-focused and extremely artistic approach. She has a young, lively and future-oriented design vision.

Diplomata nel 2018 alla scuola Italiana Design di Padova, si dedica da subito al furniture design con un approccio progettuale focalizzato sulla persona ed estremamente artistico. Una visione di design young, vivace e proiettato al futuro.

Projects: Mies, Vice-versa, Brezza, Rosie, Gio, Dori



Antonio Fattore

Designer

He holds a degree in Design from the IED in Milan in 2014. His furnishings combine contemporary aesthetic taste with the formal suggestions deriving from his multidisciplinary background and in-depth studies of manufacturing processes.

Diplomatosi in Design allo IED di Milano nel 2014, progetta arredi in grado di coniugare il gusto estetico contemporaneo e le suggestioni formali derivanti dal suo background multidisciplinare e dai suoi studi approfonditi dei processi produttivi.

Projects: Arsenale, Circus, Nobu



PARK Associati

Architects

Founded in 2000 by Filippo Pagliani and Michele Rossi, Park Associati focuses on architecture, urban planning, landscape, interior design and product design. At the studio, design is an open process that feeds on dialogue and combines analysis and intuition.

Fondato nel 2000 da Filippo Pagliani e Michele Rossi, Park Associati si occupa di architettura, urbanistica, landscape, interior design e product design. Nello studio, la progettazione è un processo aperto che si nutre di dialogo e combina analisi e intuizione.

Projects: Mella Collection



Mirco Cavallo

Designer

In 1999 he founded his own studio SuperStudio21 in Cologne, Germany. His studio deals with various themes, from Architecture to Design, from Graphics to Art; all disciplines that involve experimentation and love for one's work.

Nel 1999 fonda il suo studio SuperStudio21 a Colonia in Germania. Il suo studio affronta diverse tematiche, dall'Architettura al Design, dalla Grafica all'Arte; discipline che implicano sperimentazione ed amore per il proprio lavoro.

Projects: Moka

/ the designers

volume 6.0 | INNOVA



Monica Graffeo

Designer

She has been involved in design since 1997 with a strong multidisciplinary vocation. Since this time she has been involved in product development and art direction, working with numerous furniture companies, from bathrooms to decorative objects, to office and home furnishings.

Si occupa di design dal 1997 con una spiccata vocazione multidisciplinare. Ha da allora collaborato, occupandosi di sviluppo prodotto e di direzione artistica, con numerose aziende dell'arredo, dal bagno all'oggettistica, dall'ufficio alla casa.

Projects: Bands collection

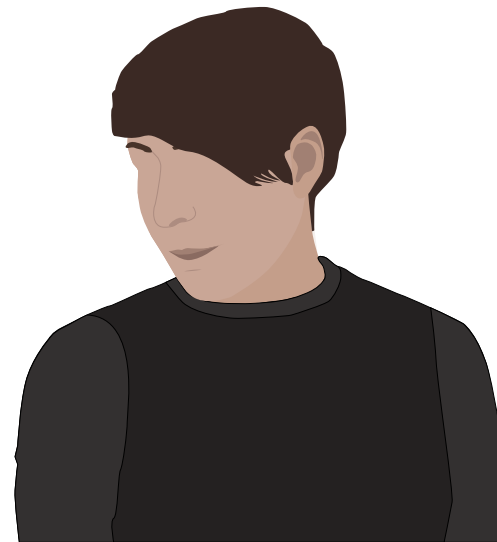

Fabrizio Citton

Designer

Designer and founder of Arter&Citton, an architecture and design practice. His design work extends into various fields, such as architecture, design, interior design, communication and visual selling.

Progettista, fonda lo studio Arter&Citton, che si occupa di architettura e design. È attivo nella progettazione estesa in varie aree disciplinari, quali l'architettura, il design, l'interior design, la comunicazione e il visual selling.

Projects: Kat, Adam, Kyo, Sgabby, Bisy

INNOVA Srl

Via Meucci, 17 - 35011 Campodarsego (PD) - Italy
tel. +39 049 9200500

commerciale@innovaimbottiti.com
www.innovaimbottiti.com

